

AUTOCAD Training

Trainer : **Soon**

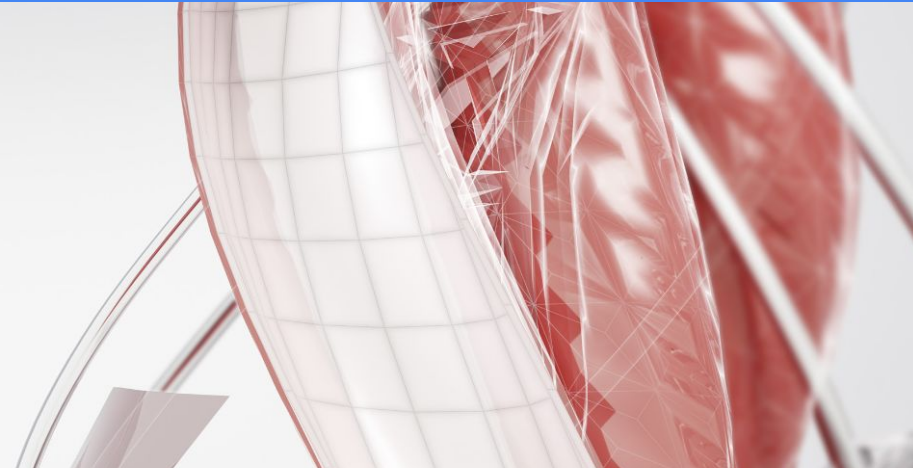

AutoCAD Modules

Module 1: Basic Shape Drawing & Setup

- Introduction to AutoCAD's User Interface (UI)
- Mastering Line and Circle Drawing
- Effortless Control:
Move, Copy, Rotate, Mirror, and Trim Tools

Module 2: AutoCAD Configuration

- Advanced Features Elevating
- Linetype and Text Style
- Hatch Pattern Setting
- Dimensioning and Layout Configuration
- Mastering Array Techniques

Module 3: Basic 3D

- 2D Elevation Drawing
- Basic 3D Drawing
- View Control & Visual Style
- Extrude, Union, Subtract,
Presspull

Module 4: Advance 3D & Assignment

- 3D Polyline
- Sweep Command
- Loft Command
- Revolve Command
- Array Path

Module 5: 3D Floorplan & Materials

- Convert 2D Drawing to 3D
- Title Block Attribute
- Material Library
- Customized Material



5 Days AUTOCAD Training

Modules Timeline

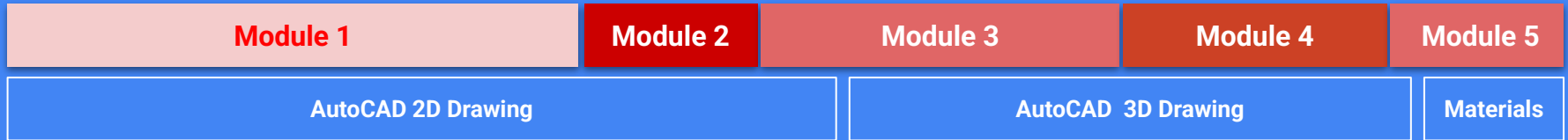

What is AutoCAD

AutoCAD is a computer-aided design (CAD) software widely used in architecture, engineering, and construction industries. It enables users to create precise 2D and 3D drawings, aiding in design, drafting, and documentation. Its features include a user-friendly interface, extensive libraries, and tools for efficient project visualization and collaboration.



Who Should Learn Autocad



- 1. Architects:**
AutoCAD is a fundamental tool for architects to create precise floor plans, elevations, and 3D models of buildings.
- 2. Civil Engineers:**
Civil engineers use AutoCAD to design infrastructure projects like roads, bridges, and drainage systems.
- 3. Mechanical Engineers:**
AutoCAD is essential for creating detailed mechanical drawings and 3D models for machines and parts.
- 4. Interior Designers:**
Interior designers use AutoCAD to create room layouts, furniture designs, and interior decorating plans.
- 5. Electrical Engineers:**
AutoCAD can be used for electrical schematics and wiring diagrams in the design of electrical systems.

Before Start Drawing

1. Unit Configuration

2. Zoom & Pan



Before Start Drawing

Drawing Units

Length
Type: Decimal
Precision: 0.0000

Angle
Type: Decimal Degrees
Precision: 0
 Clockwise

Insertion scale
Units to scale inserted content: Millimeters

Sample Output
1.5,2.0039,0
3<45,0

Lighting
Units for specifying the intensity of lighting: International

OK Cancel Direction... Help

1. Unit Configuration

UN

Drawing unit defines the measurement system for distances and sizes in a drawing, which can specify unit type, precision, and angle measurement for the types like architectural, decimal, engineering, or scientific.

Type	Description	Accuracy	Example: L 22.5
Architectural	Whole feet and inches	Whole inches up to 1/256 of the in	1'-10 1/2"
Decimal	Decimal units	0-8 decimal digits	22.500
Engineering	Whole feet and inches	0-8 decimal digits of the inch	1'-10.5"
Fractional	Integral no. & fragment	Integral no. up to 1/256 of the unit	22 1/2
Scientific	Exponential	0-8 decimal digits	2.250E+01

2. Zoom & Pan



Zoom

Roll the mouse wheel button

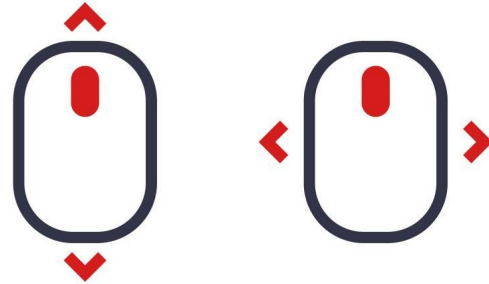

Pan

Drag and hold the center mouse wheel button.

Module 1

Part 1



Module 1

1. **Introduction to AutoCAD's User Interface (UI)**
Familiarize the user interface, including the Ribbon for tools, the Command Line for direct input, and the Drawing Area as your main workspace.
2. **Mastering Line and Circle Drawing**
Learning LINE and CIRCLE commands and practice using precision tools like Object Snap and Grids

3. **Effortless Control: Move, Copy, Rotate, Mirror & Trim Tools**
Utilize key tools for effortlessly moving, copying, rotating, mirroring, and trimming objects to optimize your workflow.



Module 1

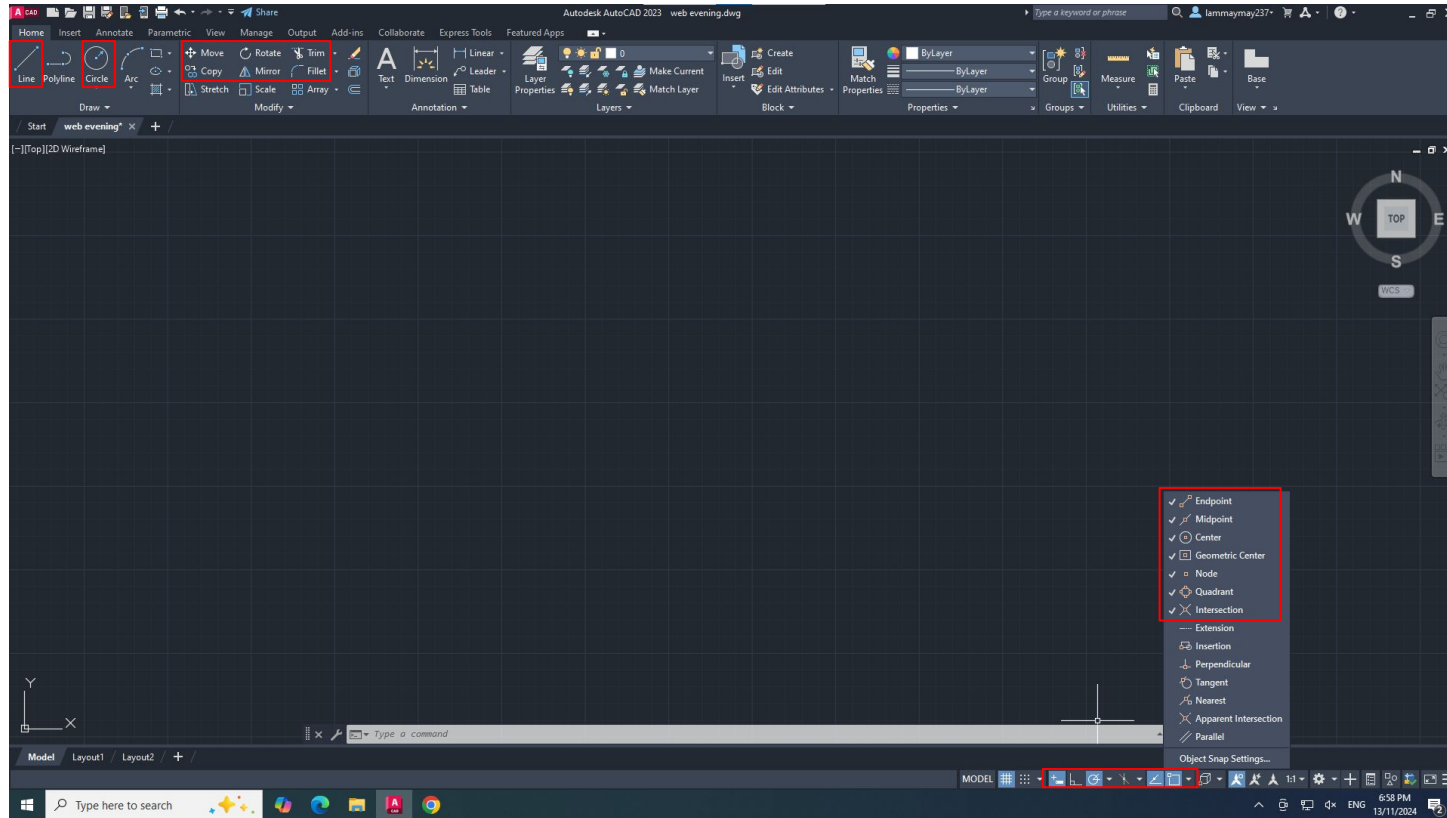

Module 1 Basic Drawing Tools

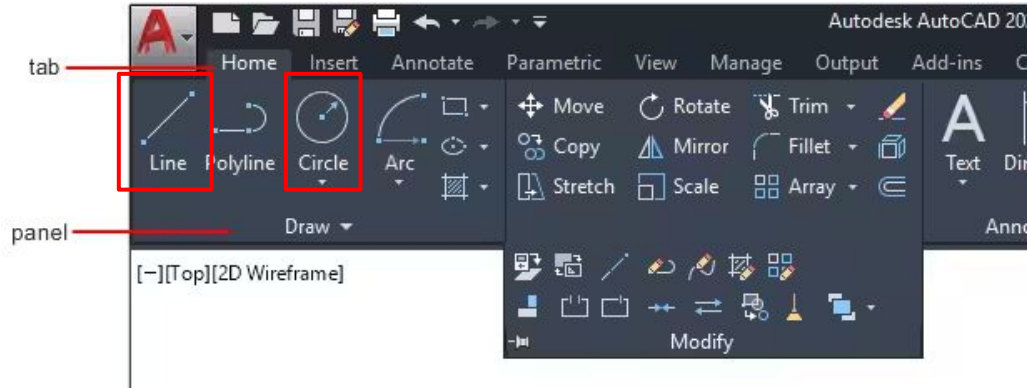

Line

LIN

Circle

CI

line is a straight path defined by two points, while a **circle** is a closed curve where all points are equidistant from a center point.

Module 1 Snap & Tracking Functions

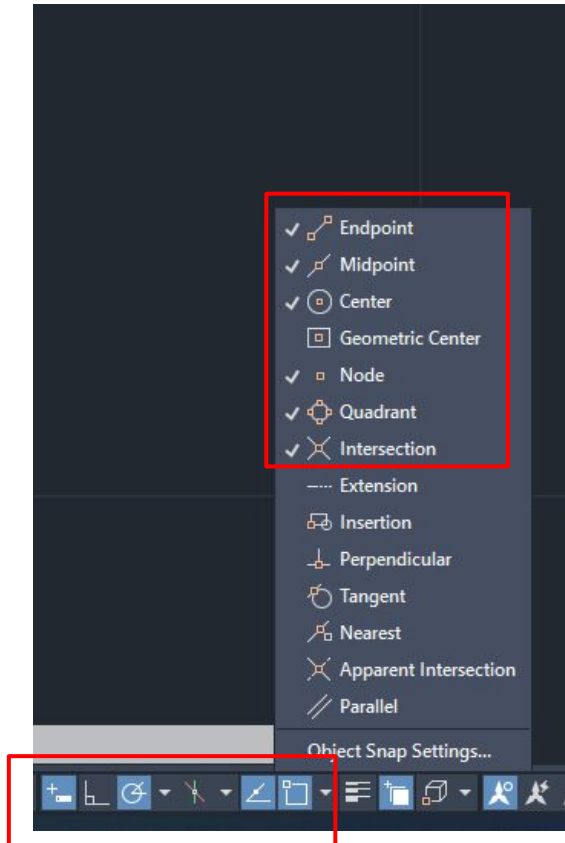

Dynamic Input /Dynmode **F12**

Polar Tracking **F10**

Object Snap Tracking **F11**

Object Snap **F3**

Module 1 Snap & Tracking Functions

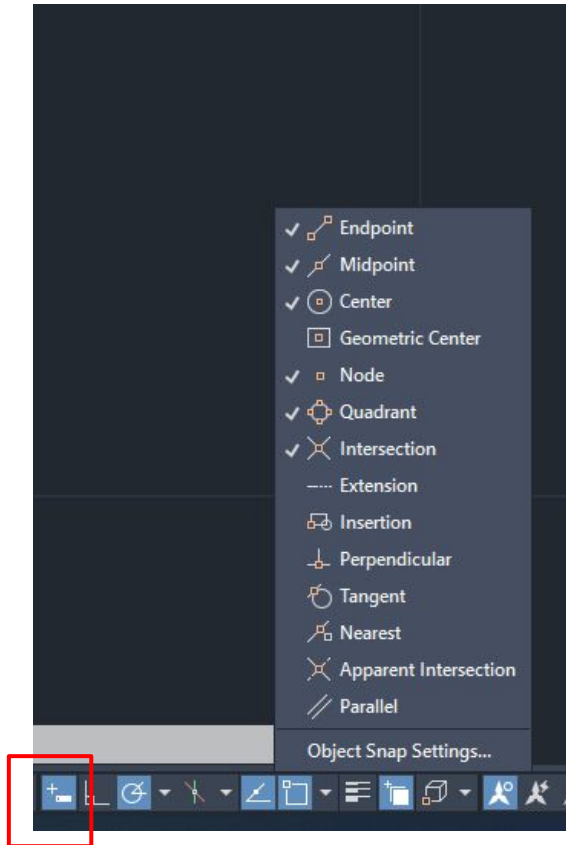

Dynamic Input /Dynmode **F12**

Dynamic Input in AutoCAD is a feature that displays command prompts, options, and input fields directly near the cursor, allowing users to interactively enter values, commands, and modify objects without needing to look at the command line.

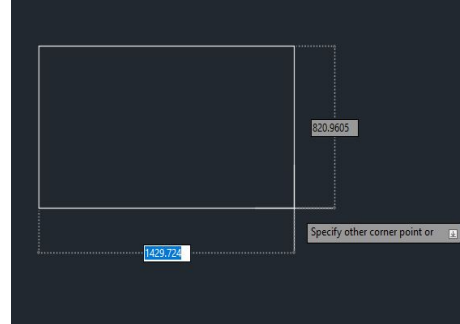

With Dynamic Input



Without Dynamic Input

Module 1 Snap & Tracking Functions

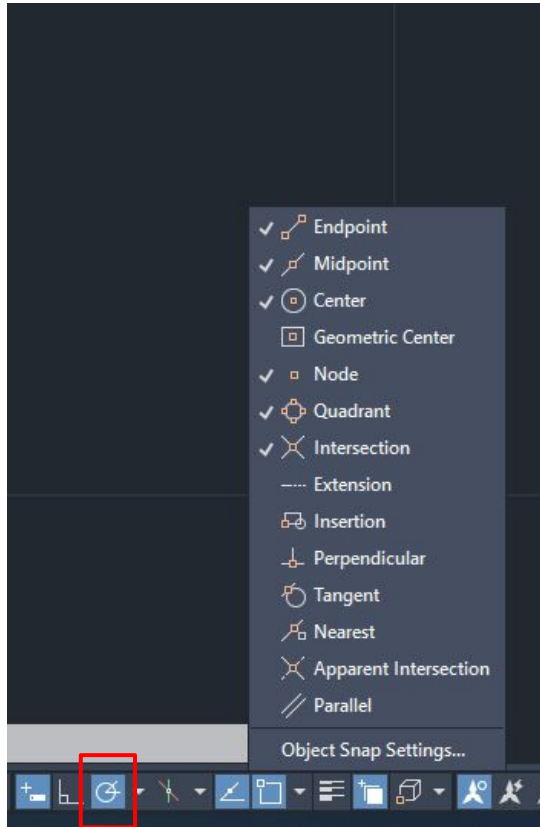

Polar Tracking

F10

The **Polar Tracking** Line is a green indicator line that shows specified angles relative to the X, Y, or Z (3D) axis, helping to maintain precise alignment and direction when drawing or modifying objects.

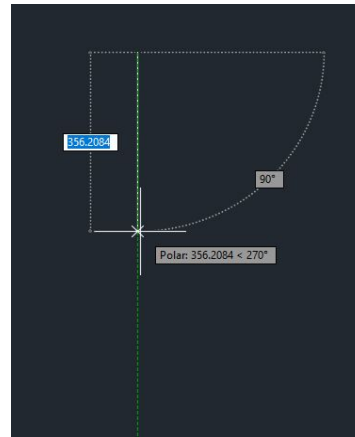

With Polar Tracking

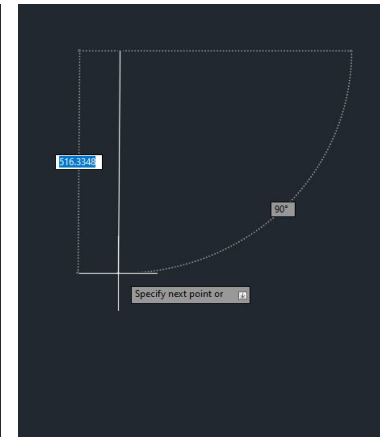

Without Polar Tracking

Module 1 Snap & Tracking Functions

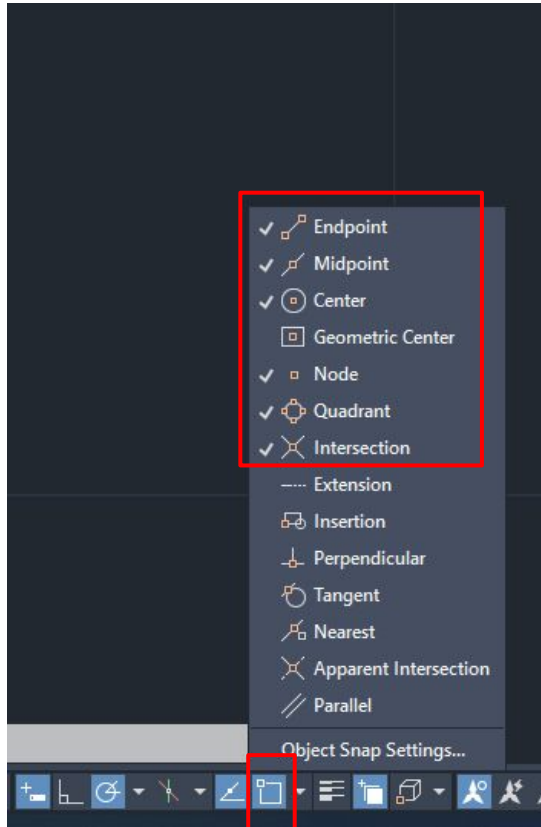

Object Snap **F3**

Object Snap in AutoCAD helps you snap to precise points on objects, like endpoints or midpoints, for accurate drawing and editing. It ensures proper alignment and positioning, improving precision in your work.



Module 1 Basic Features

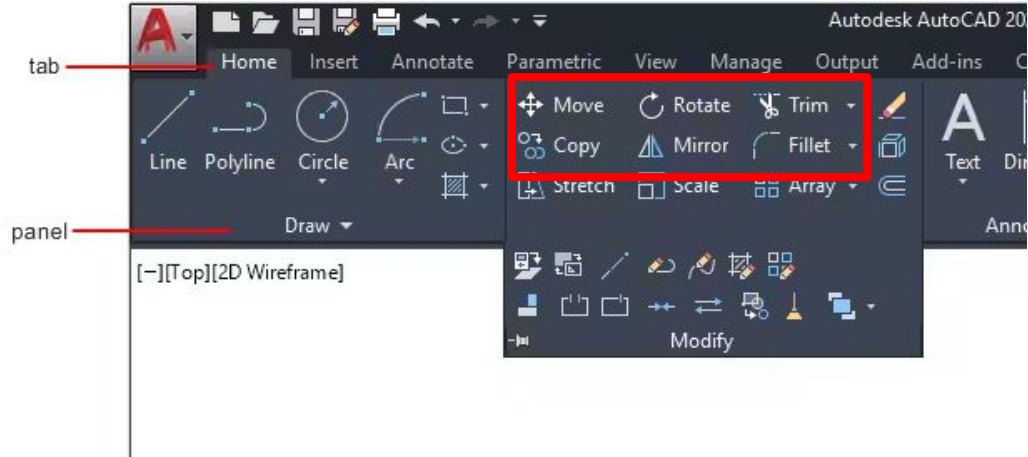

Move

MO

Copy

CO

Trim

TR

Rotate

RO

Mirror

MIR

Module 1

Exercise 1



Module 1 Exercise 1

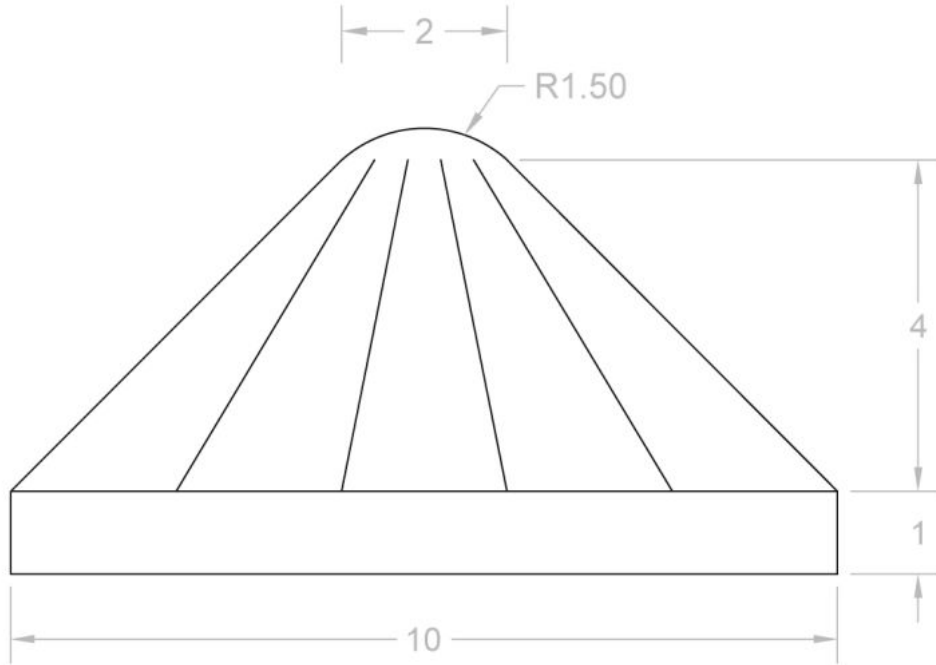

What will you learn?

1. Line Drawing **LIN**
2. End & Midpoint Snap
3. Node Snap
4. Divide & Point Type **DIV / PTY**
5. Blue & Green Box Selection
6. Arc Drawing

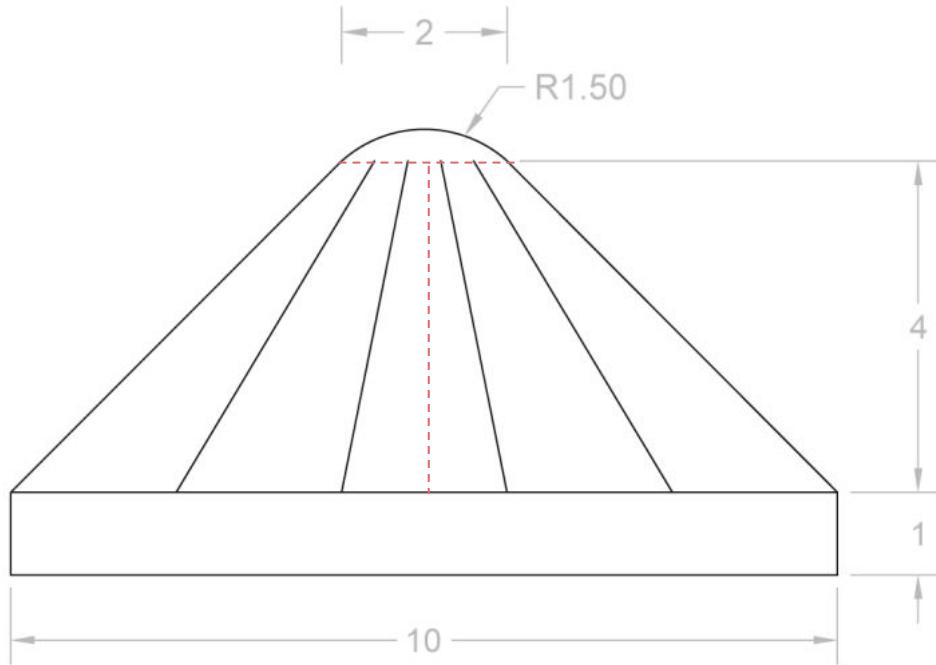

Why Guideline?

1. They Provide Reference for Accurate Drawing
 - a. **Snap** to known points.
 - b. Create **intersections, midpoints, or alignments** with other elements.
 - c. **Mirroring** is easier and more precise.
 - d. They Are Essential for **Scaling** and Proportions

Module 1 Endpoint & Midpoint

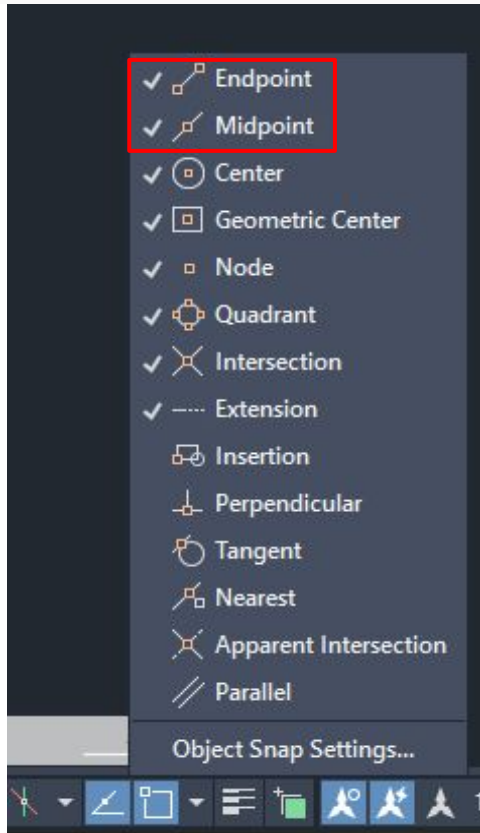

End Point

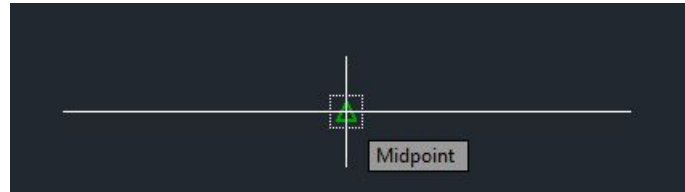
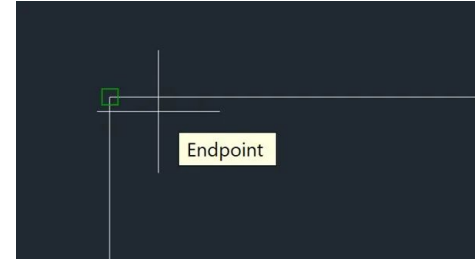

Mid Point

In AutoCAD, the **End Point** is a geometric reference that marks the terminal point of a line or arc, while the **Mid Point** is the point located at the center of a line or arc.

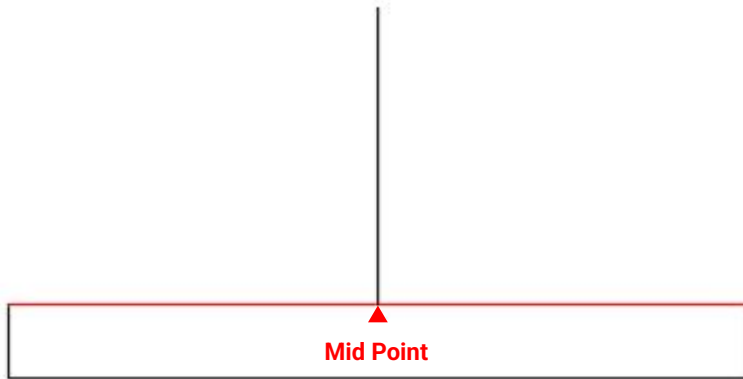

What will you learn?

1. Line Drawing
2. End & Midpoint Snap
3. Node Snap
4. Divide & Point Type
5. Blue & Green Box Selection
6. Arc Drawing

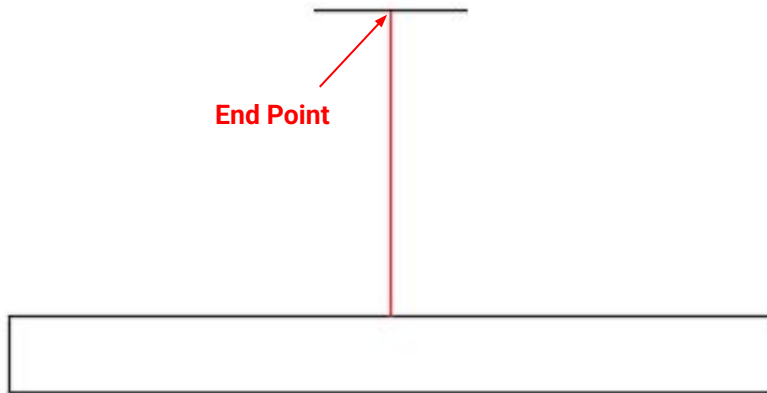

What will you learn?

1. Line Drawing
2. End & Midpoint Snap
3. Node Snap
4. Divide & Point Type
5. Blue & Green Box Selection
6. Arc Drawing

Module 1 Divide & Point Style

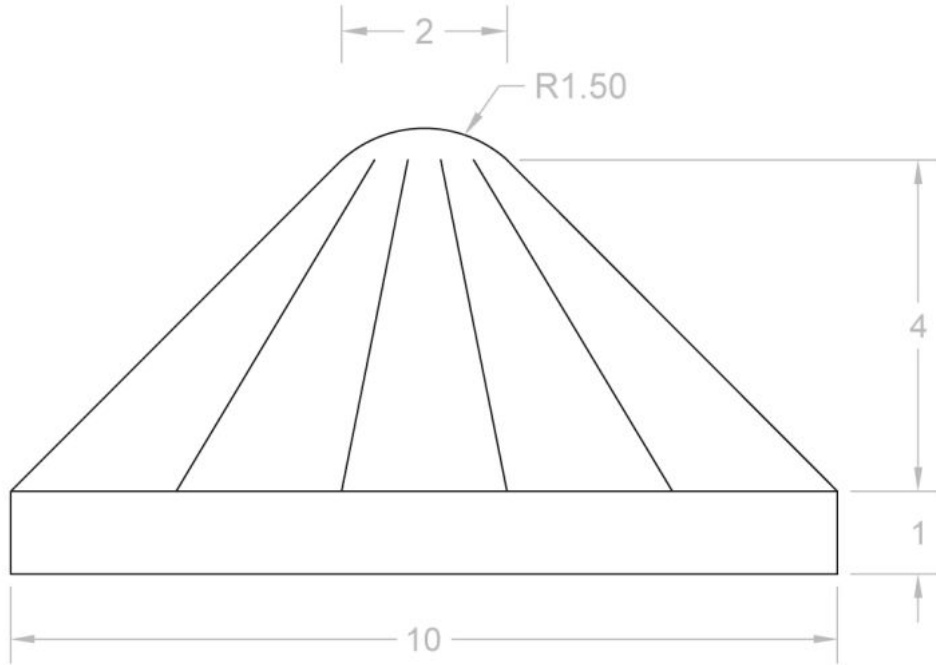

What will you learn?

1. Line Drawing
2. End & Midpoint Snap
3. Node Snap
4. Divide & Point Type **DIV / PTY**
5. Blue & Green Box Selection
6. Arc Drawing

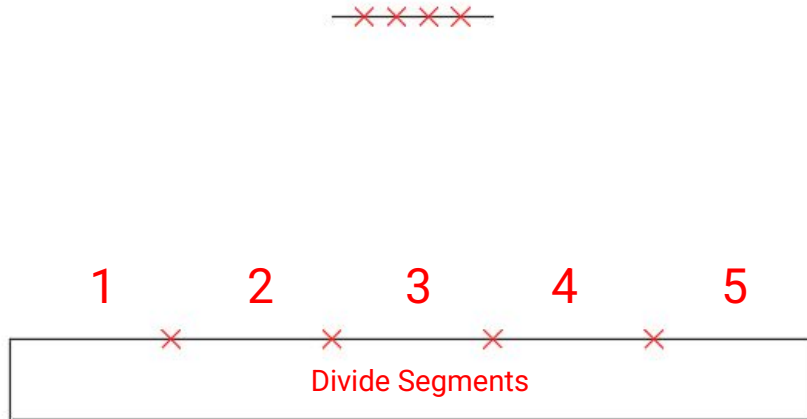

What will you learn?

1. Line Drawing
2. End & Midpoint Snap
3. Node Snap
4. Divide & Point Type **DIV / PTY**
5. Blue & Green Box Selection
6. Arc Drawing

Module 1 Node & Point Style

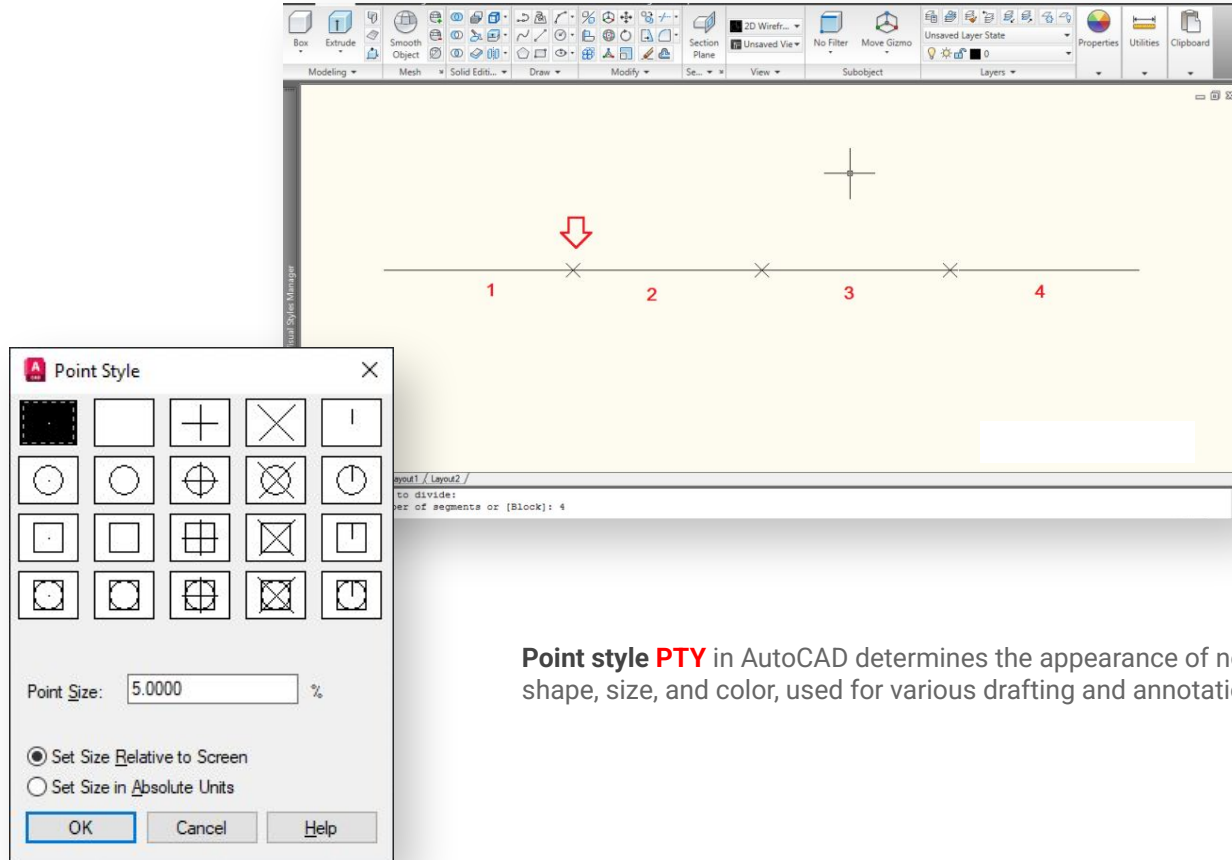

The image shows a screenshot of the AutoCAD software interface. The top ribbon contains various toolbars including Modeling, Mesh, Solid Edit, Draw, Modify, Section Plane, View, and Subobject. The main drawing area displays a horizontal line divided into four equal segments by three 'x' marks. The segments are labeled with red numbers 1, 2, 3, and 4 from left to right. A red arrow points to the first 'x' mark. A point style dialog box is open in the foreground, showing a grid of 20 different point styles. The 'Point Size' is set to 5.0000. The dialog box has two radio buttons: 'Set Size Relative to Screen' (selected) and 'Set Size in Absolute Units'. The 'OK' button is highlighted.

Point style PTY in AutoCAD determines the appearance of node point, including their shape, size, and color, used for various drafting and annotation purposes.

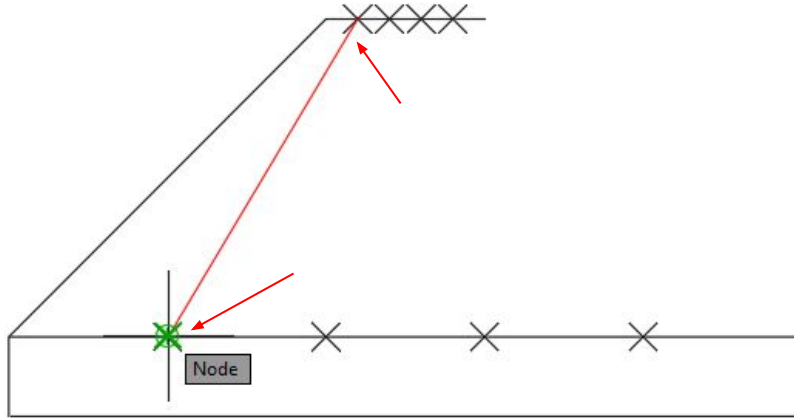

What will you learn?

1. Line Drawing
2. End & Midpoint Snap
3. Node Snap
4. Divide & Point Type
5. Blue & Green Box Selection
6. Arc Drawing

Module 1 Blue & Green Box Selection

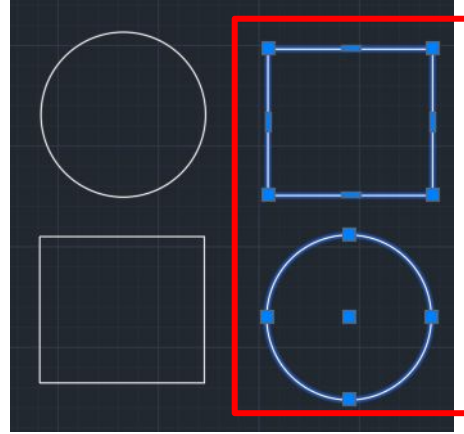
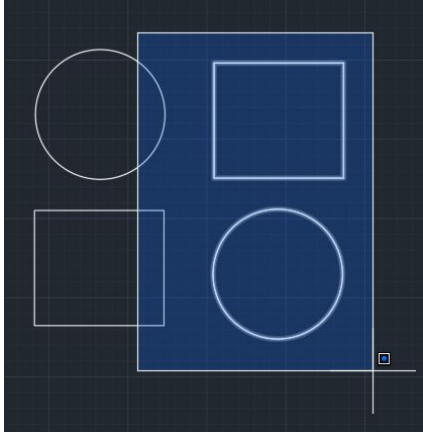

Blue box selection is **OBJECT SELECTION**, in AutoCAD refers to selecting only the objects entirely within the box.

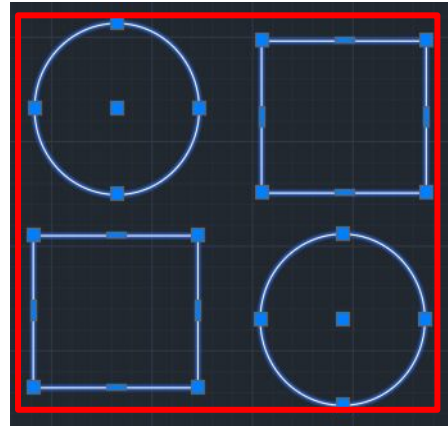
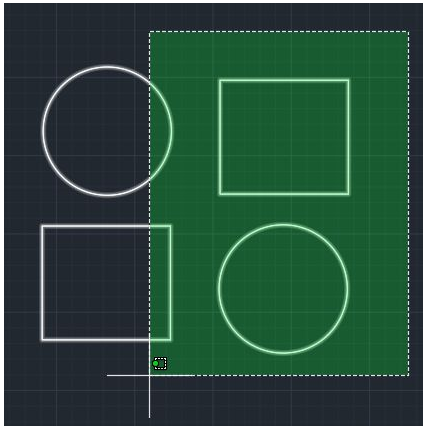

Green box selection is **AREA SELECTION**, in AutoCAD refers to selecting all objects that are either entirely or partially within the box.

Module 1 Exercise 1

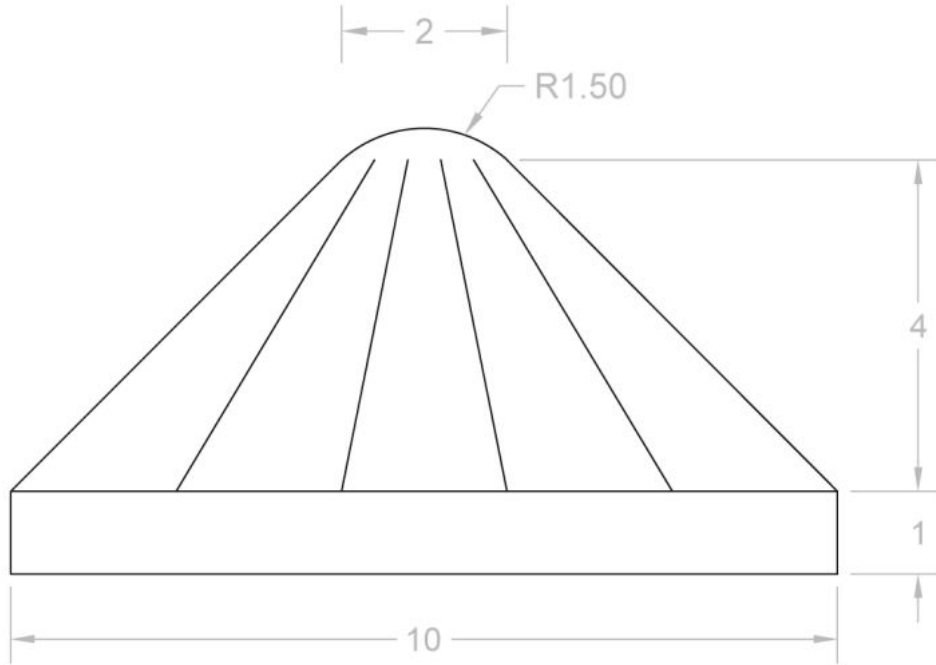

What will you learn?

1. Line Drawing **LIN**
2. End & Midpoint Snap
3. Node Snap
4. Divide & Point Type **DIV / PTY**
5. Blue & Green Box Selection
6. Arc Drawing

Module 1

Exercises 2



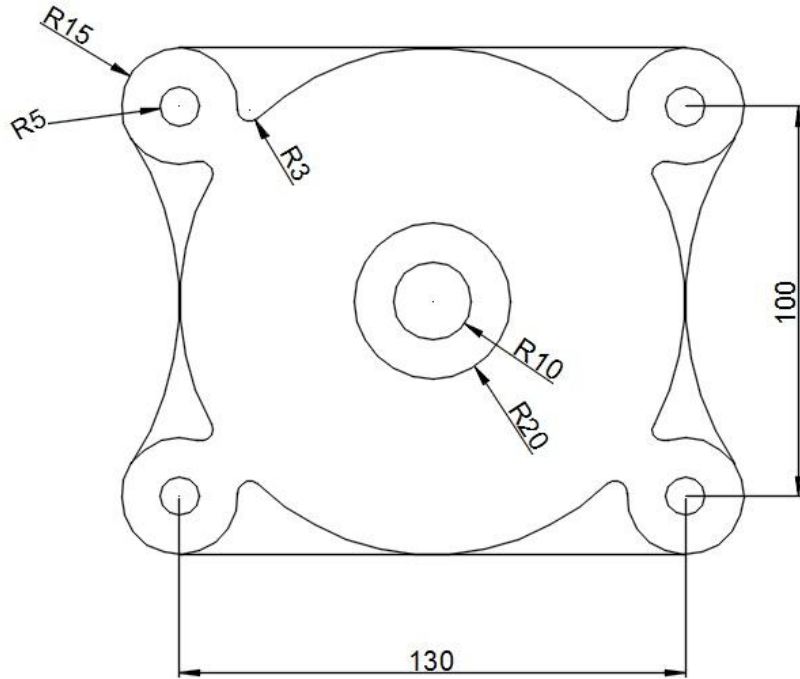

What will you learn?

1. Circle Drawing **CI**
2. Copy **COP**
3. Quadrant Snap
4. Trim **TR**
5. Fillet with Radius **F**
6. Mirror **MIR**

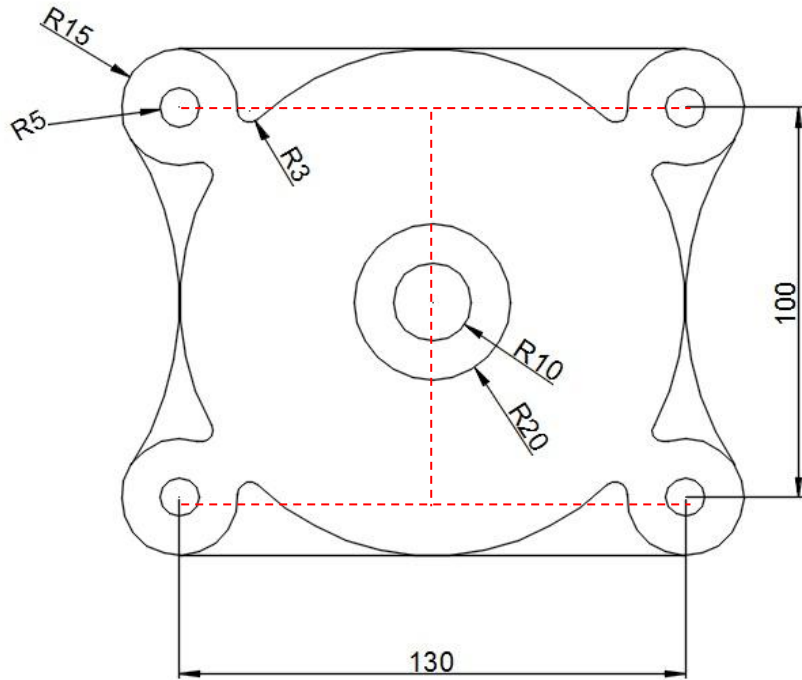

Guideline Before Drawing?

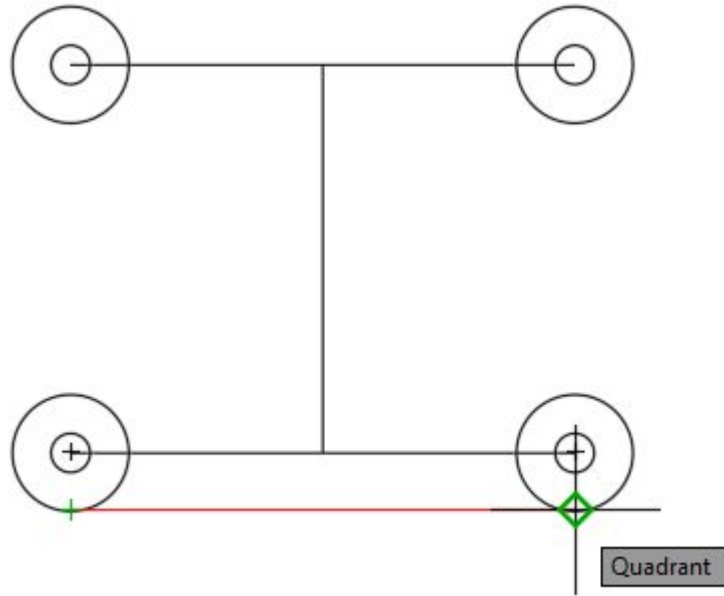

What will you learn?

1. Circle Drawing
2. Copy
3. Quadrant Snap
4. Trim
5. Fillet with Radius
6. Mirror

A **Circle Quadrant** refers to one of the four equal sections created when a circle is divided by its diameter.

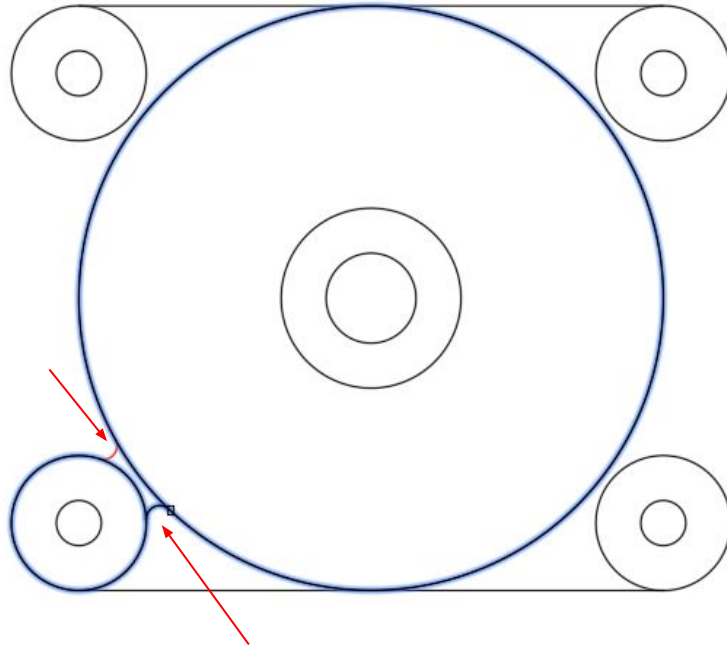

What will you learn?

1. Circle Drawing
2. Copy
3. Quadrant Snap
4. Trim
5. Fillet with Radius **F**
6. Mirror

The **Fillet F** command is used to create a rounded corner between two intersecting lines or arcs

Module 1 Fillet 4 Steps

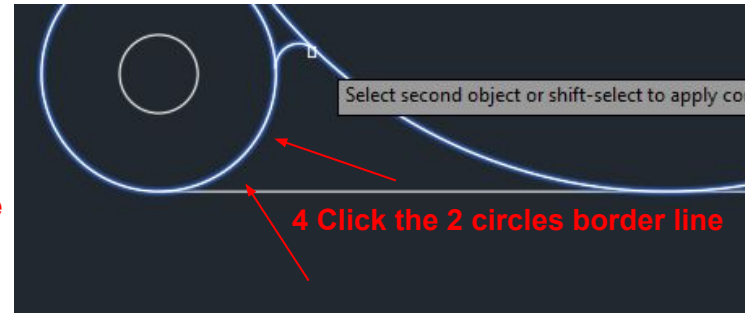
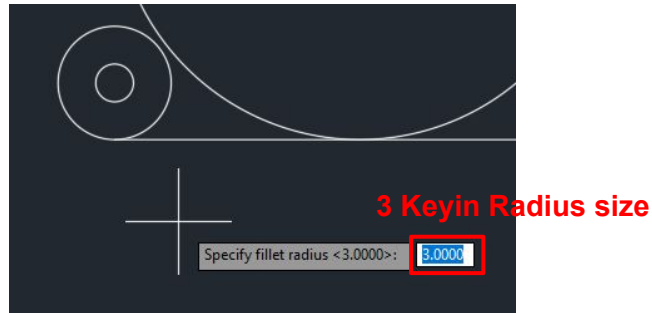
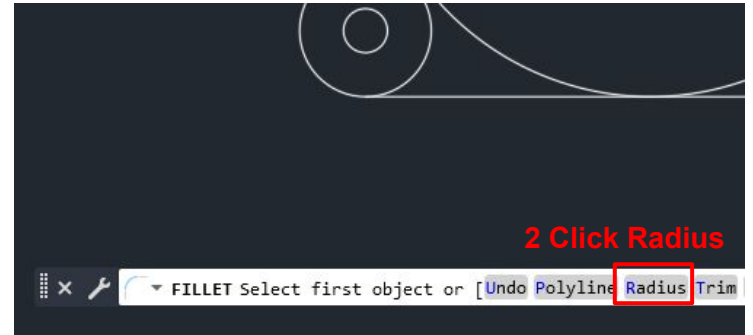
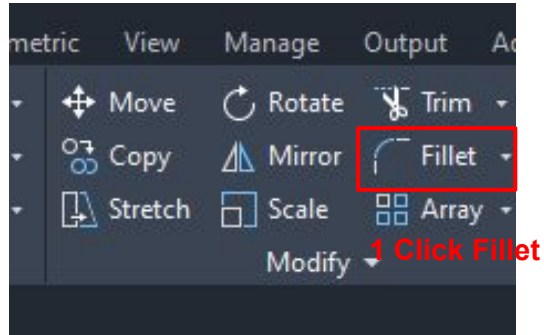

Module 1 Trim

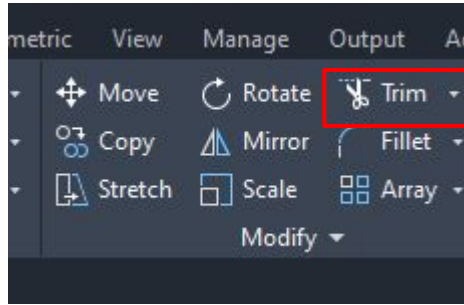

The **TRIM TR** command is used to **cut off extra parts** of a line or shape that you don't need.

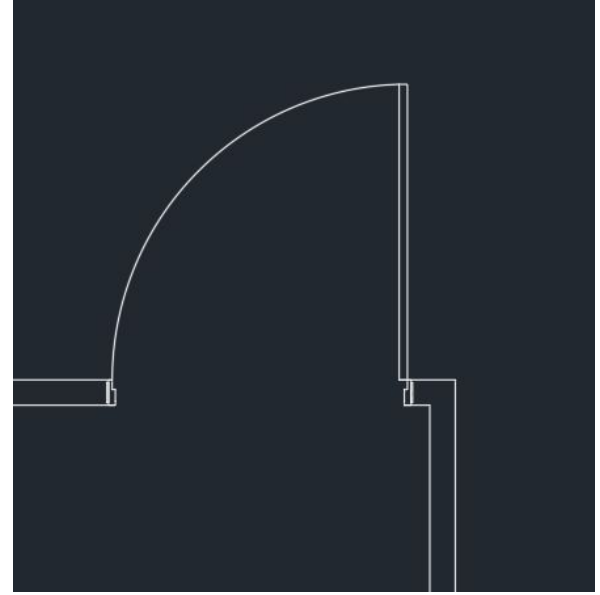
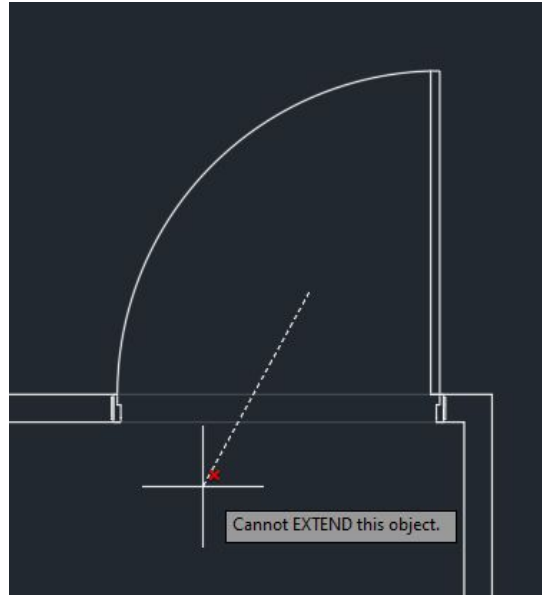

Module 1 Mirror

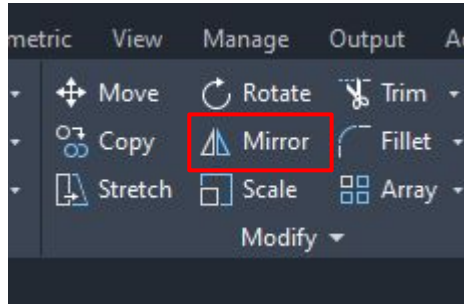

The **Mirror** **MIR** command creates a mirrored copy of selected objects across a specified axis or line, allowing for symmetrical designs and reflections without redrawing.

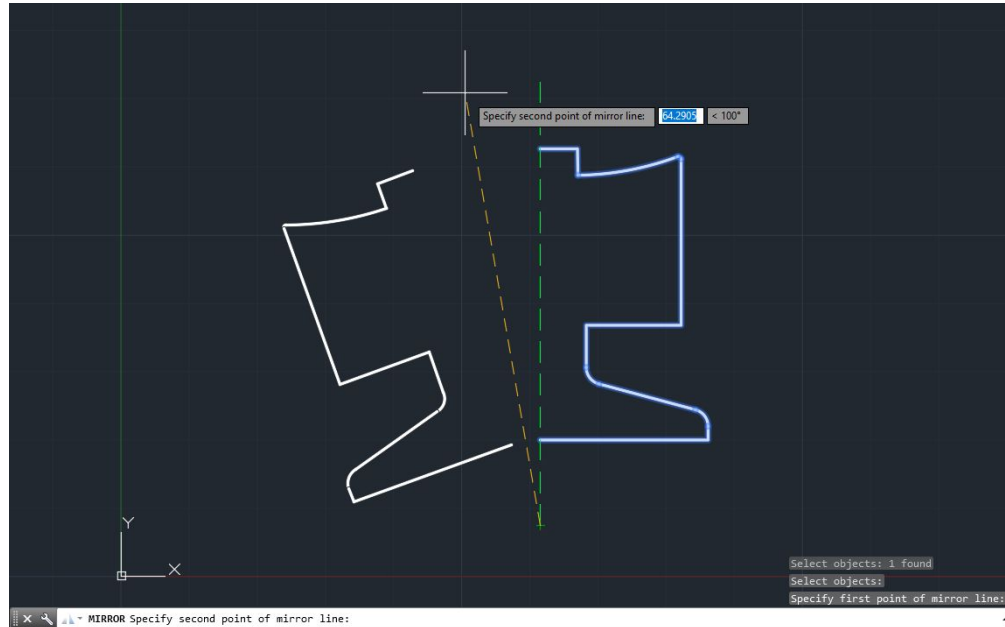

Module 1 Mirror Axis

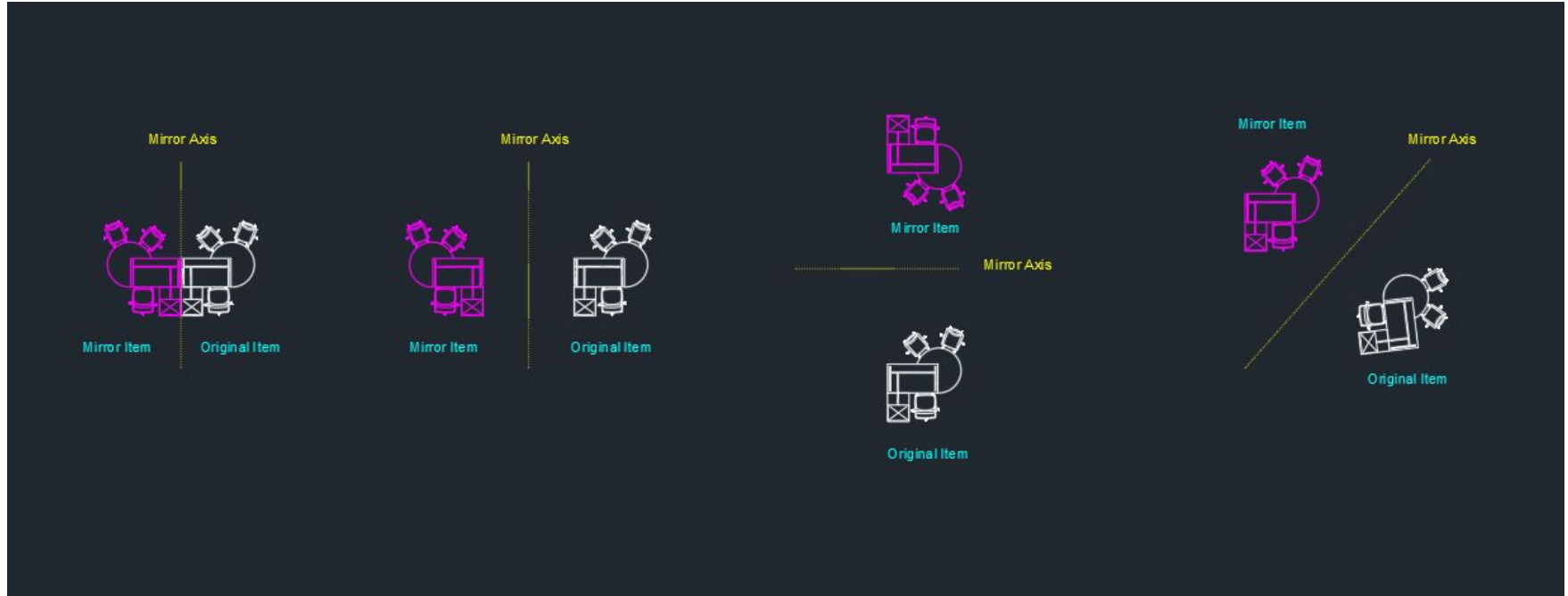

The **Mirrored Object** will be flipped across the **Mirrored Axis**. The original object remains, and a mirrored copy is created on the opposite side of the axis.

Module 1

Exercises 3



Module 1 Exercise 3

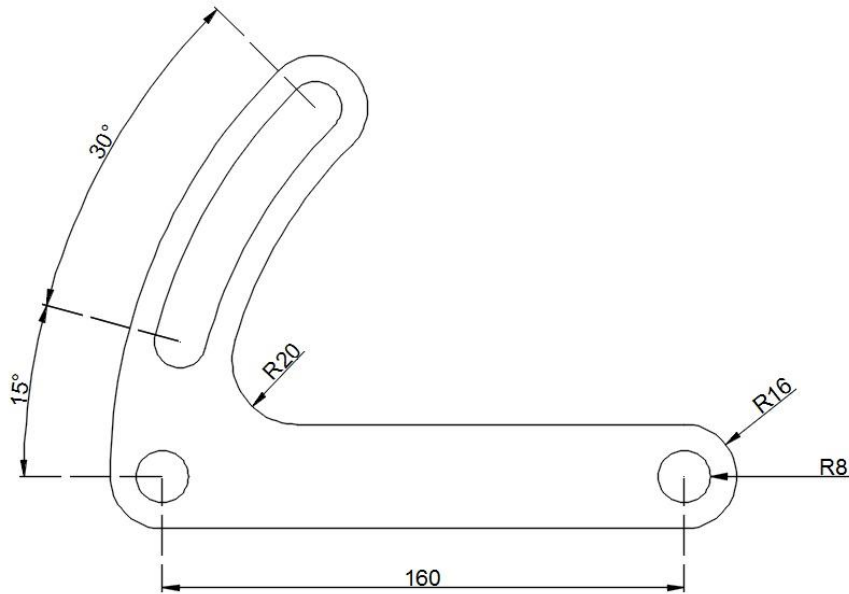

What will you learn?

1. Tracking Copy **CO**
2. Rotate **RO**
3. Fillet with Radius

Module 1 Exercise 3

reframej

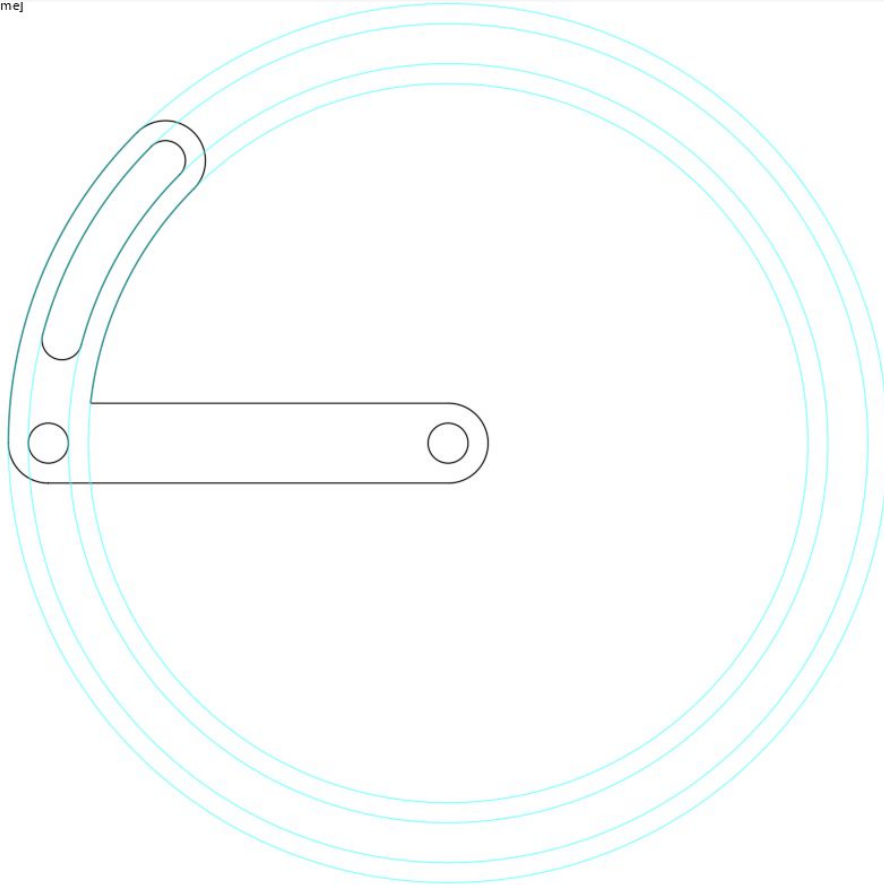

Module 1 Rotate

2 Select Rotate

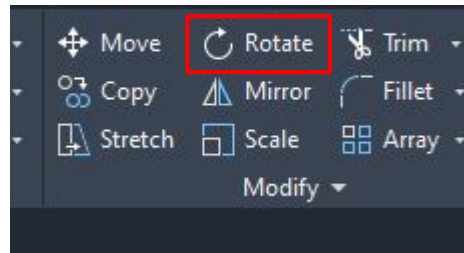

the **Rotate RO** command allows you to turn selected objects around a specified base point by a given angle, facilitating the adjustment of their orientation in the drawing.

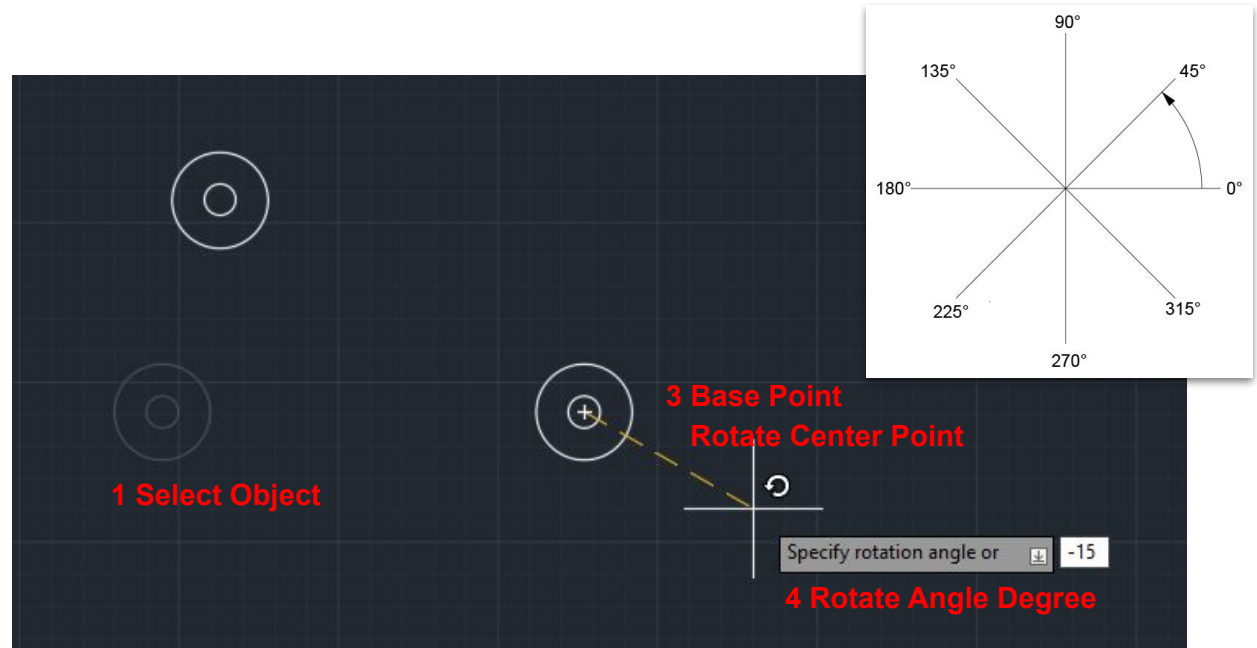

when using the **Rotate** command, a **Positive Value** for the angle rotates the object counterclockwise, while a **Negative Value** rotates it clockwise.

Module 1 Rotate Copy Option

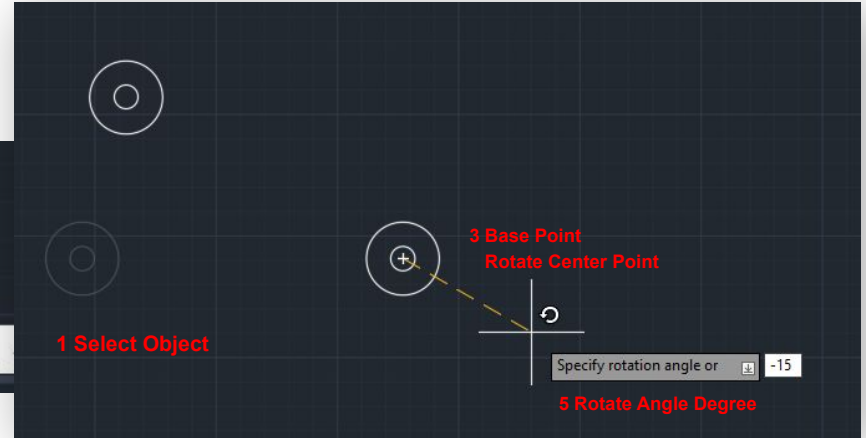
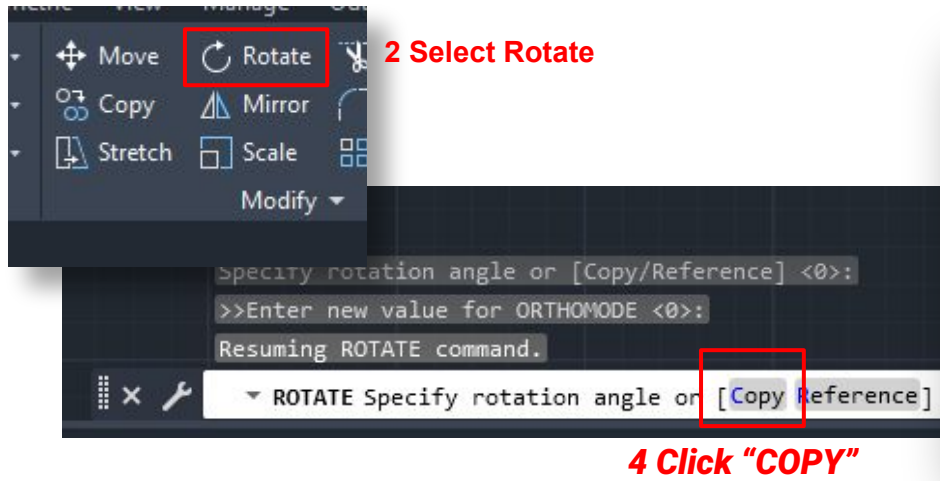

Rotate Copy: This option creates a new, rotated copy of the selected objects while keeping the original in place.

Module 1 Rotate Reference Option

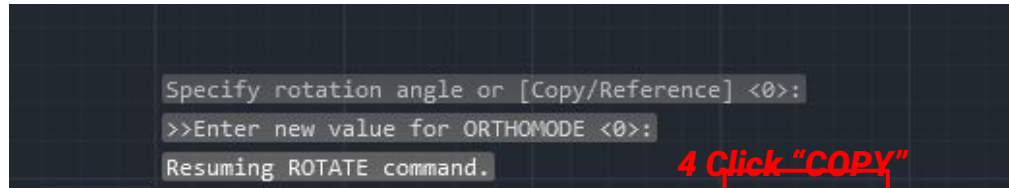
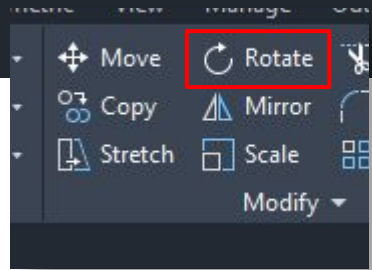
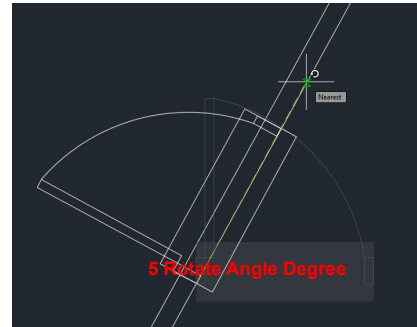
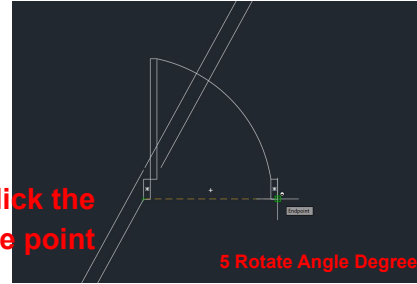

1. Rotate Reference: This option rotates the selected object by the specified angle without creating a copy, effectively changing the

Module 1

Exercises 4



Module 1 Object Snap Tracking

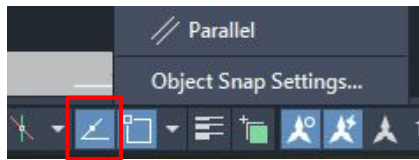
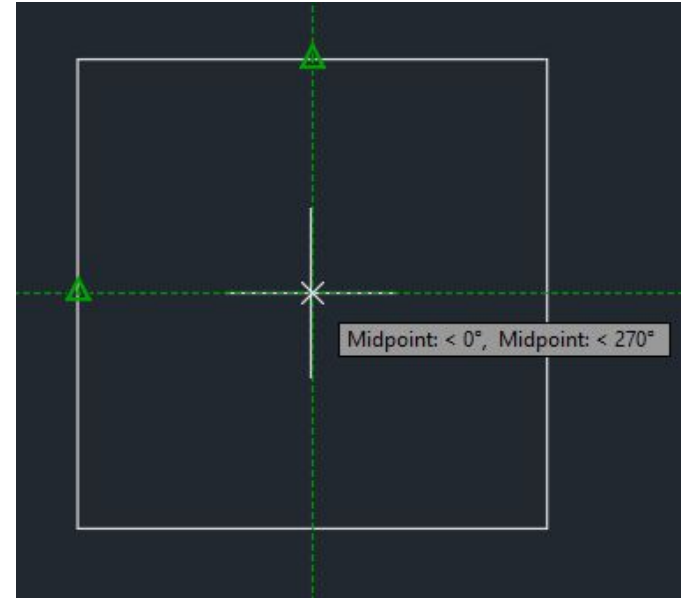
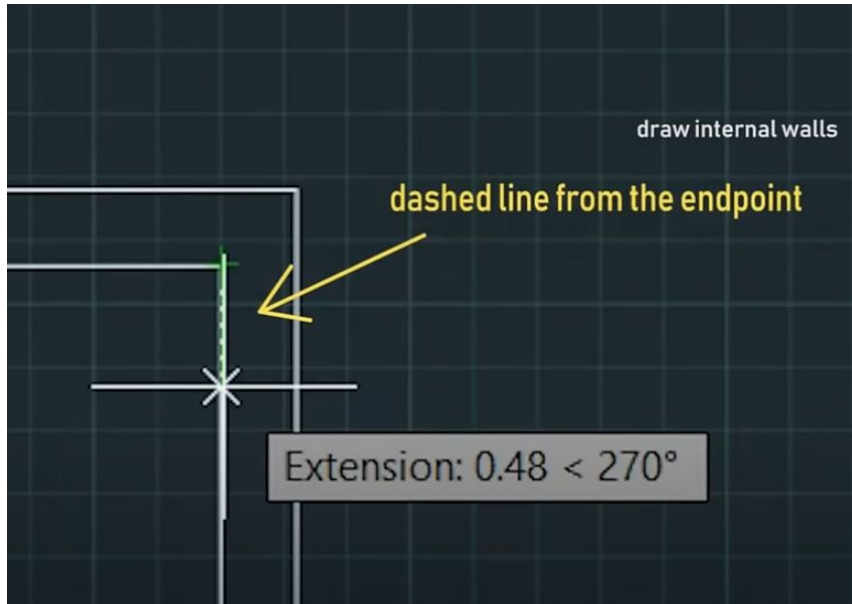

Object Snap Tracking F11 helps you create precise align tracking from the object snap points (like endpoints) to new line, shapes or object.

Module 1 Exercise 4

Exercise 1

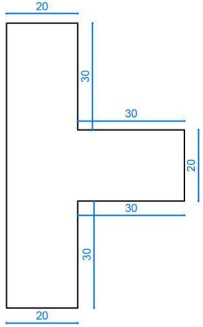

Exercise 2

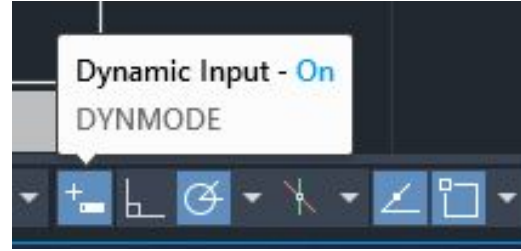
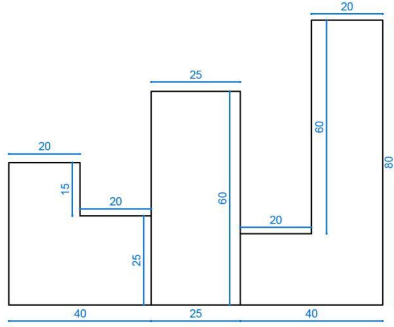

Dynamic Input F12, or Dynmode in AutoCAD, is a feature that allows users to input commands and values directly on the drawing screen. When enabled, it shows a command line near the cursor, making it easier to input commands without using the bottom command line.

Exercise 3

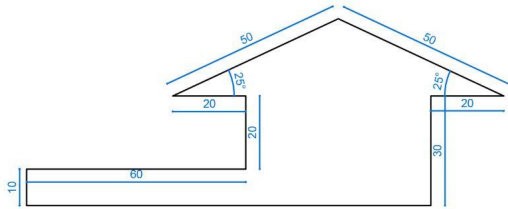

Exercise 4

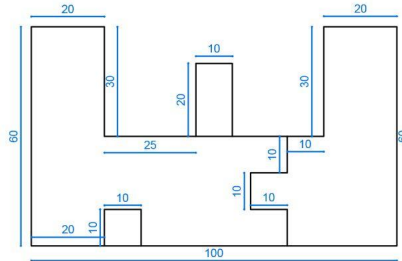

Exercise 5

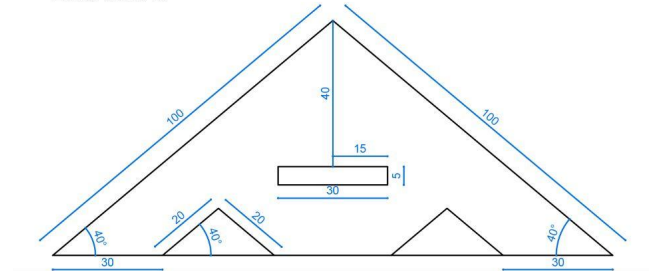

AutoCAD

Task 1



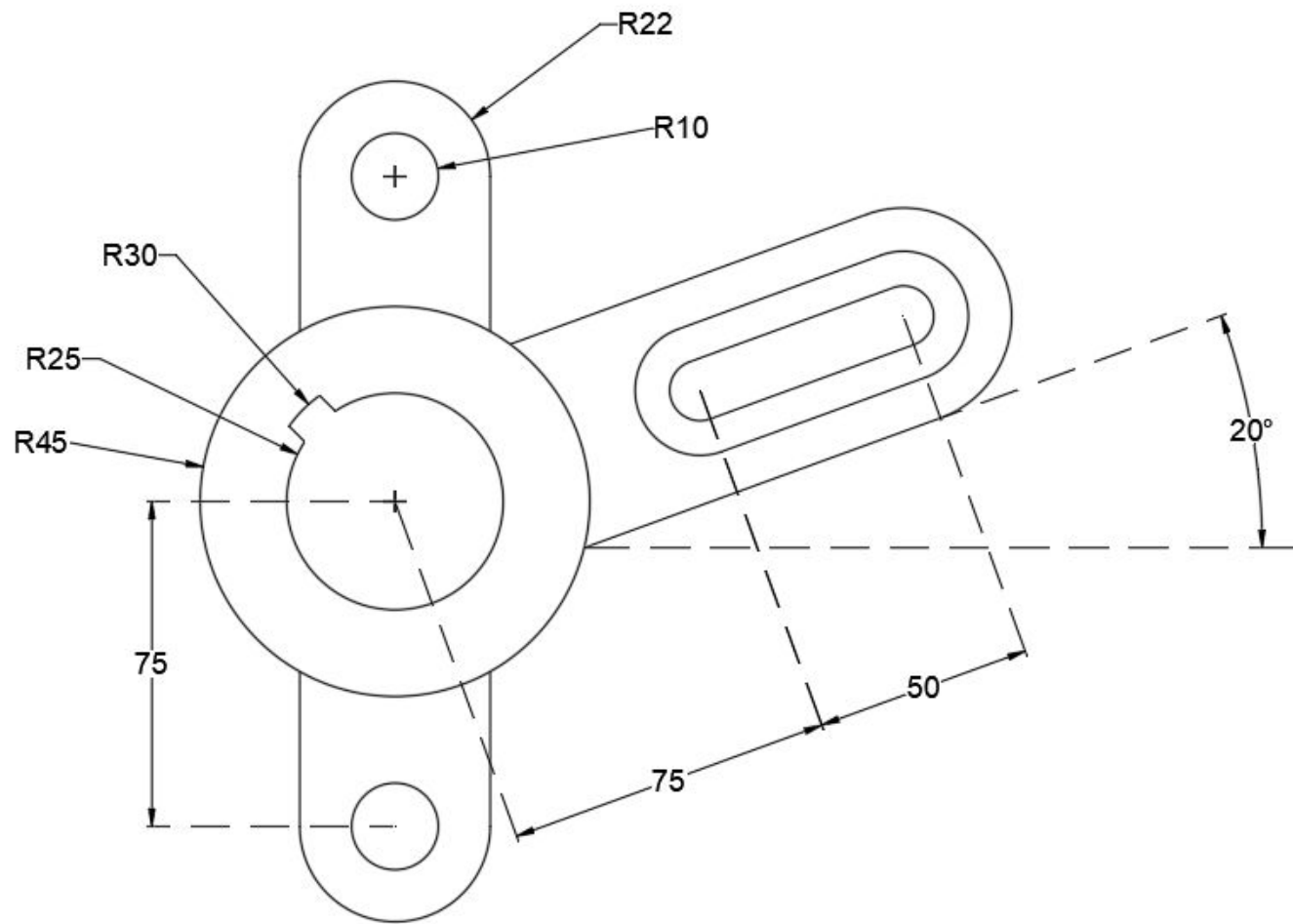

Conclusion

1. Unit Configuration **UN**
2. Zoom & Pan
3. Divide & Point Type **DIV / PTY**
4. Object Snapping **F3 / F10 / F11**
5. Blue / Green Selection
6. Copy, Mirror, Rotate, Fillet **COP / MIR / RO / F**
7. Trim Object **TR**



Module 1

Part 2



Module 1

Part 1

1. **Advanced Features Elevating**
Explore creative in hatching textures
2. **Linetype**
Focus on managing, customizing, and assigning linetypes
3. **Precision Dimensioning and Layout Configuration**
Master precision by configuring your drawing layout and skillfully inserting dimensions.

Part 2

1. **Mastering Array Techniques - Polar and Rectangular Arrays**
The polar array creates symmetrical circular arrangements around a center point, while the rectangular array generates precise grids of objects in rows and columns.

Part 3

1. **Text Style Syllabus**
Text Style controls the appearance of text, including font, size, and formatting.

Module 1

Part 2



Module 2 Hatch

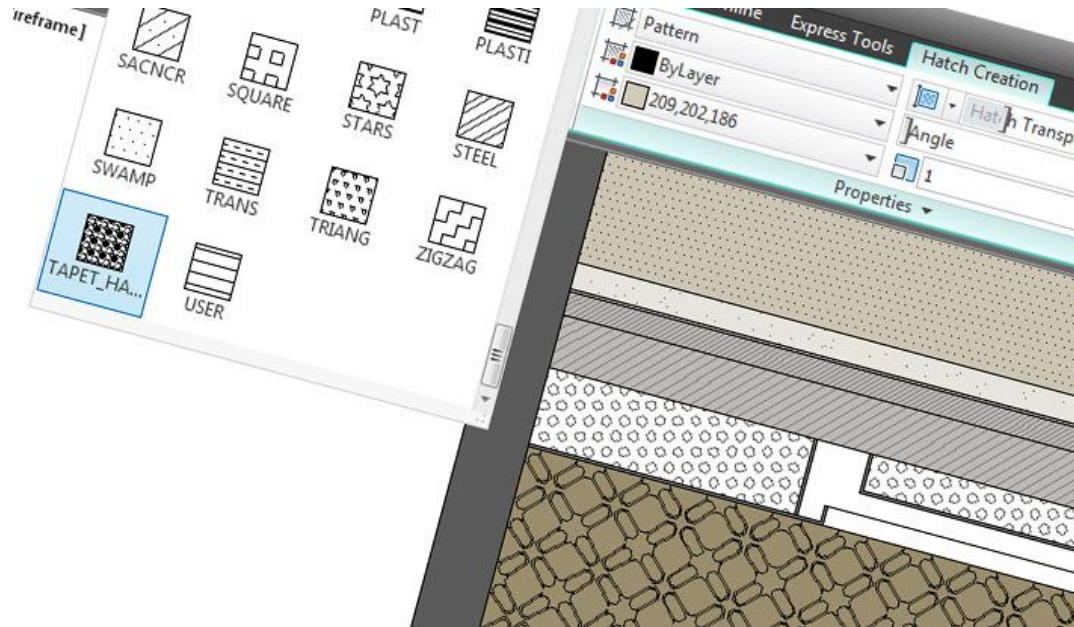

Hatch

HAT

In AutoCAD, hatch is patterns or colors to distinguish materials or sections in a drawing. It can be applied to closed shapes and customized in terms of scale, angle, and transparency.

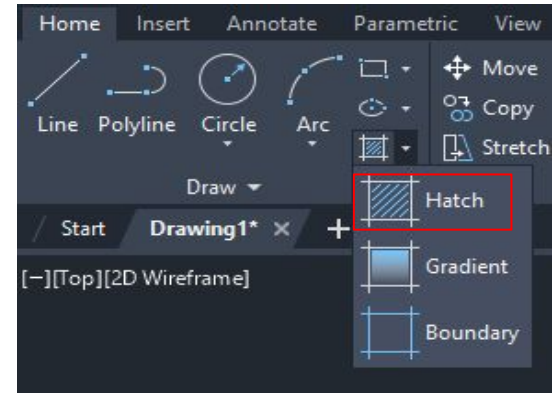

Module 2 Dimension

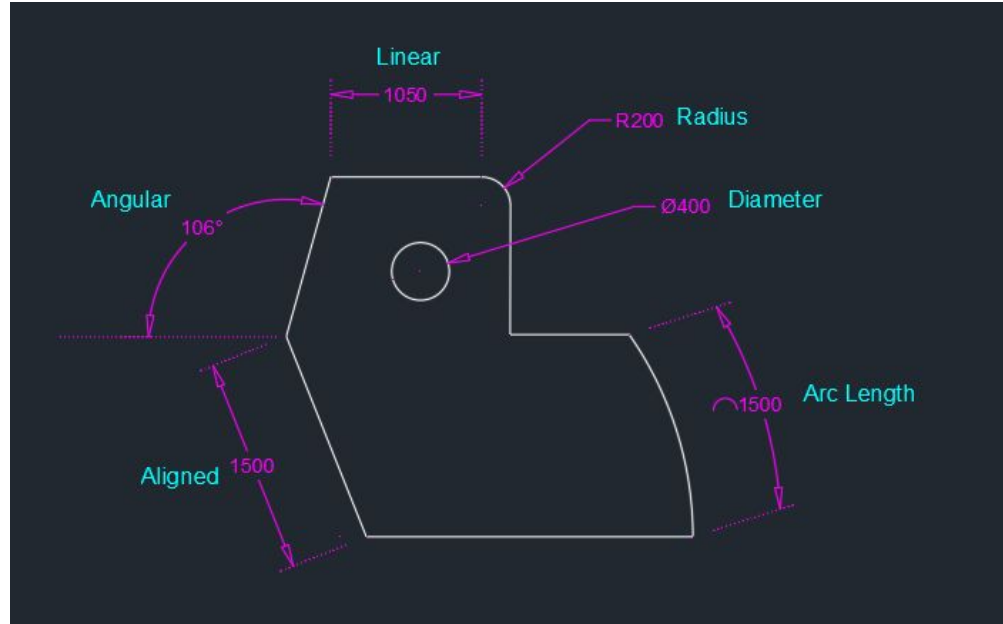
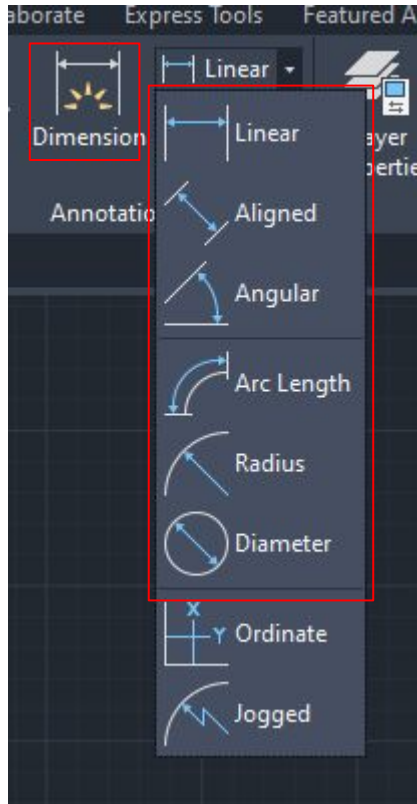

Dimension DIM in AutoCAD involves creating annotations to show the size, location, and orientation of objects. This includes various types like linear, aligned, angular, radial, and diameter dimensions.

Module 2 Dimension Style

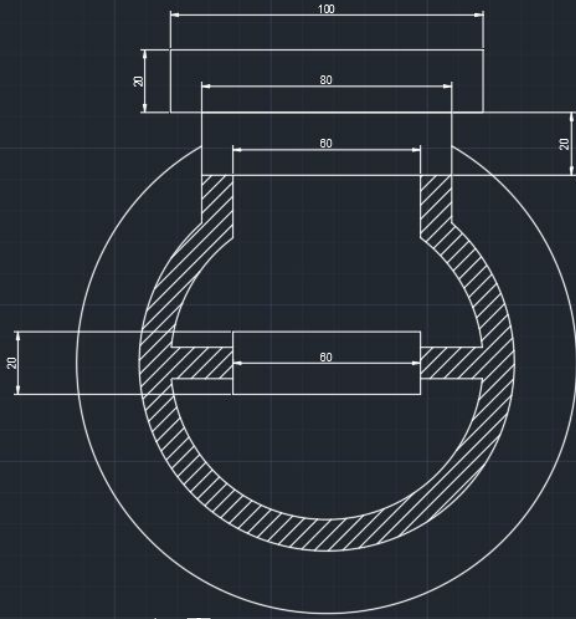

1. Text
2. Symbols & Arrow
3. Lines

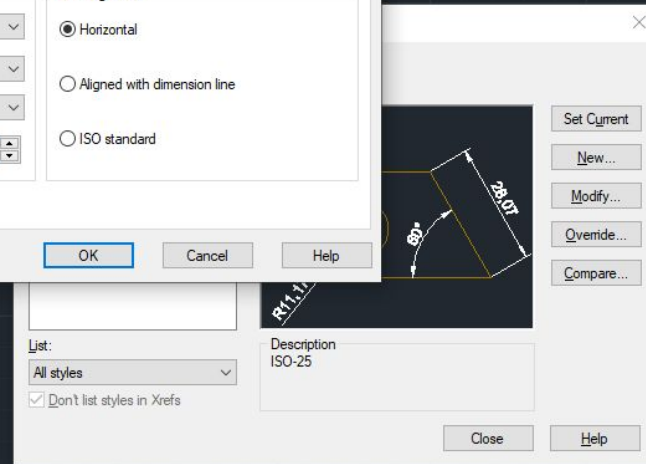
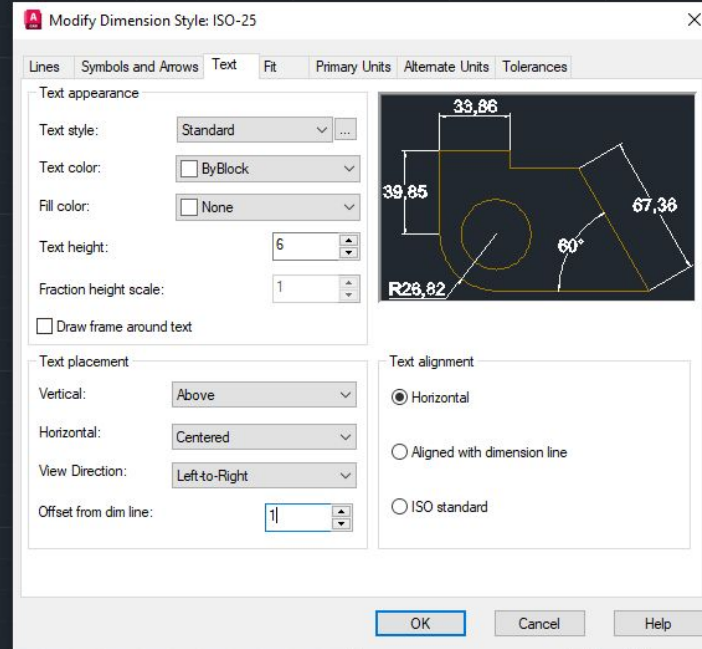

Module 2 Linetype Manager

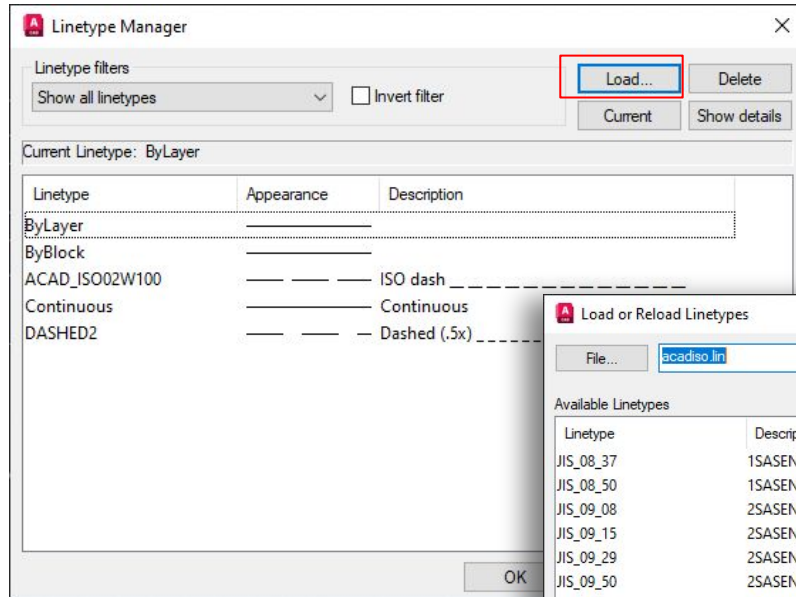

Linetype Manager LINET in AutoCAD allows users to manage and customize line appearances by defining new linetypes, modifying existing ones, and importing linetypes from external files. It enables the assignment of specific linetypes to objects, adjustment of linetype scales, and setting default linetypes for new layers, enhancing the readability and organization of drawings.

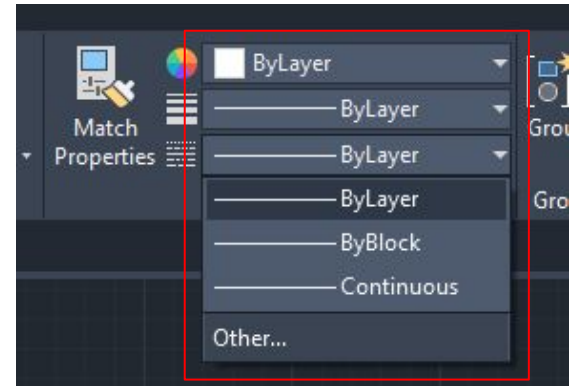
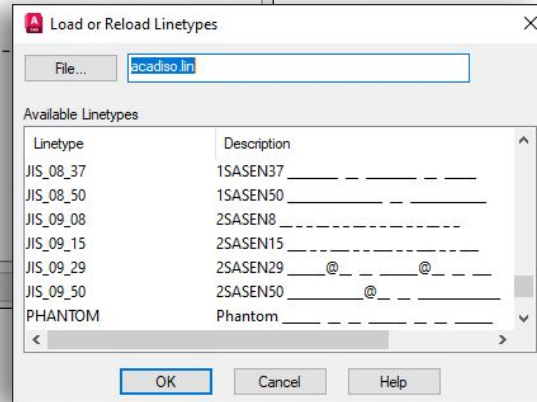

Module 1

Exercise 5



Module 2 Exercise 1

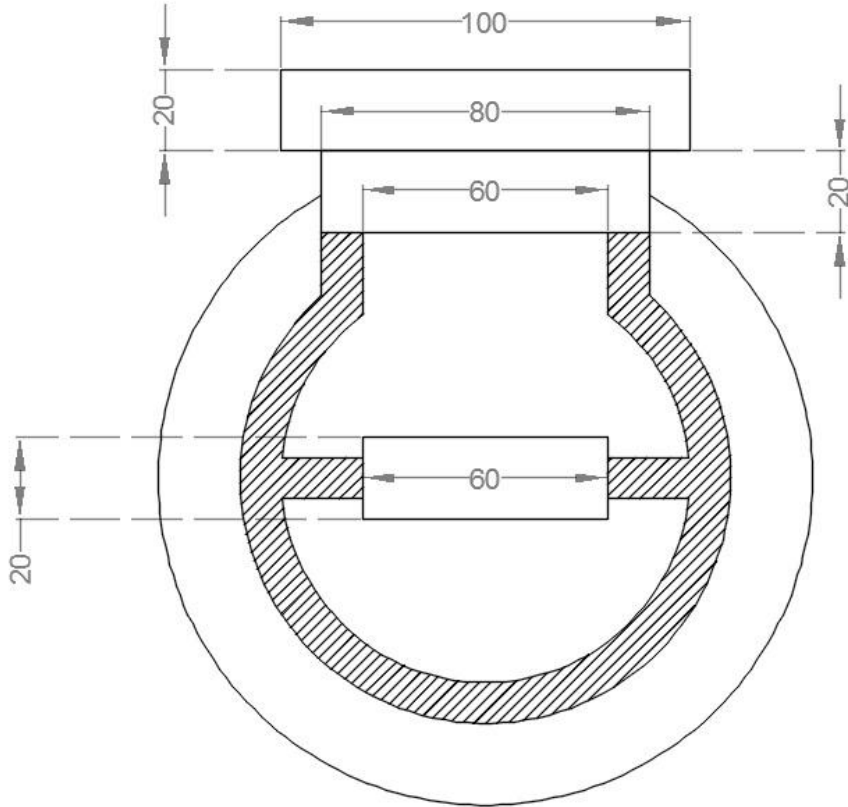

What will you learn?

1. Move **MOV**
2. Hatch **HAT**
3. Dimension Style **DIMST**
4. Line Style **LINET**

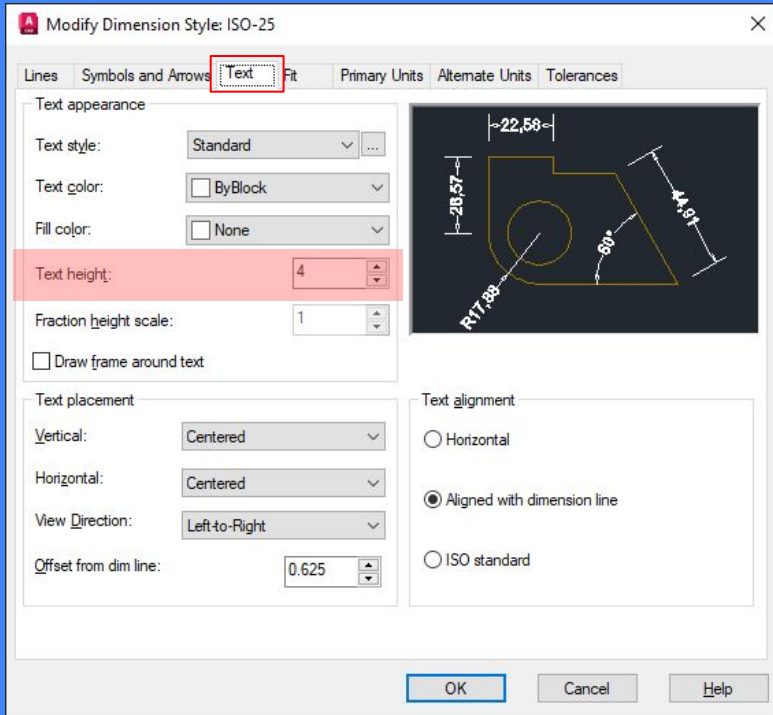

Dimension Style - Text

Text Appearance - Text Height

The **Height** determines how large or small the text will appear on the drawing when plotted or viewed on screen.

Module 2 Dimension Style - Text

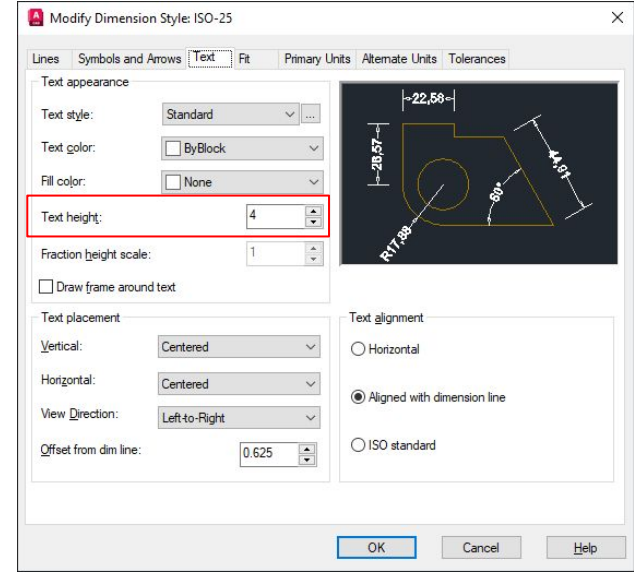
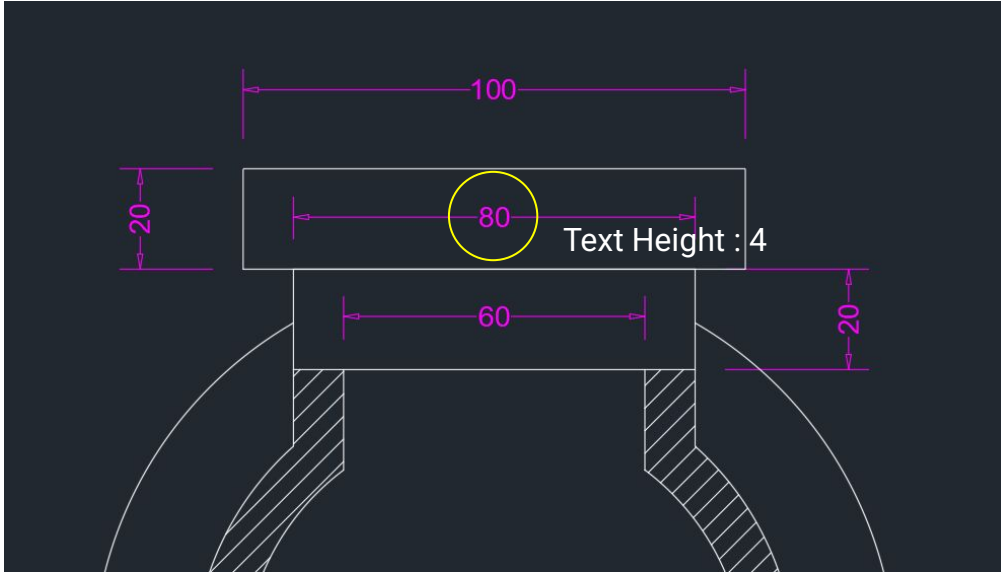

Module 2 Dimension Style - Text

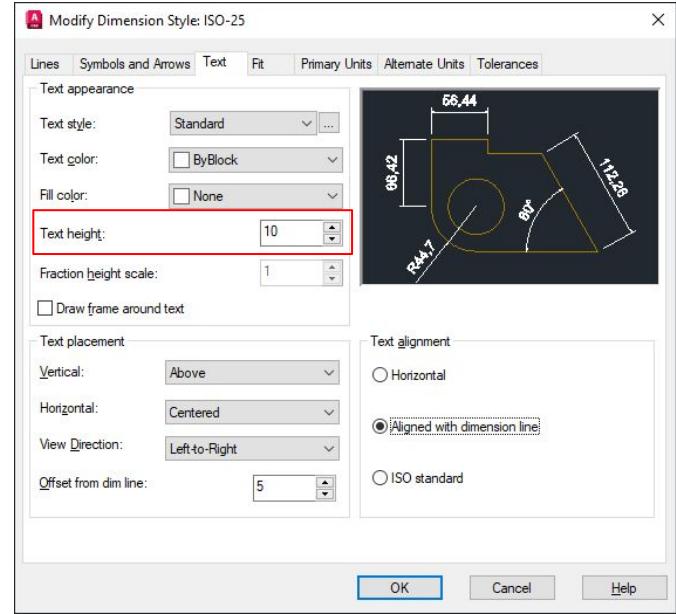
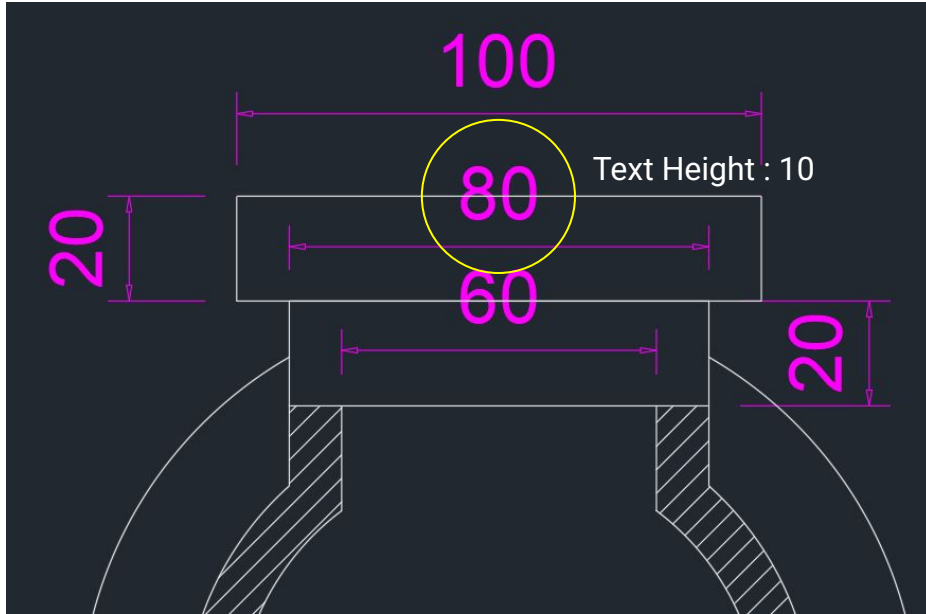

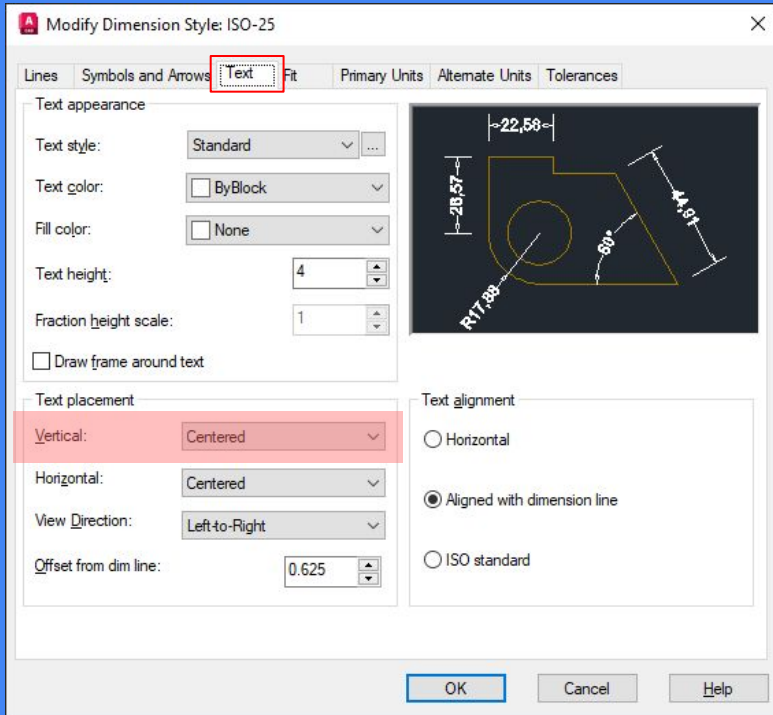

Dimension Style - Text

Text Placement - Vertical

Text Vertical refers to positioning text so that it is oriented vertically rather than horizontally.



Module 2 Dimension Style - Text

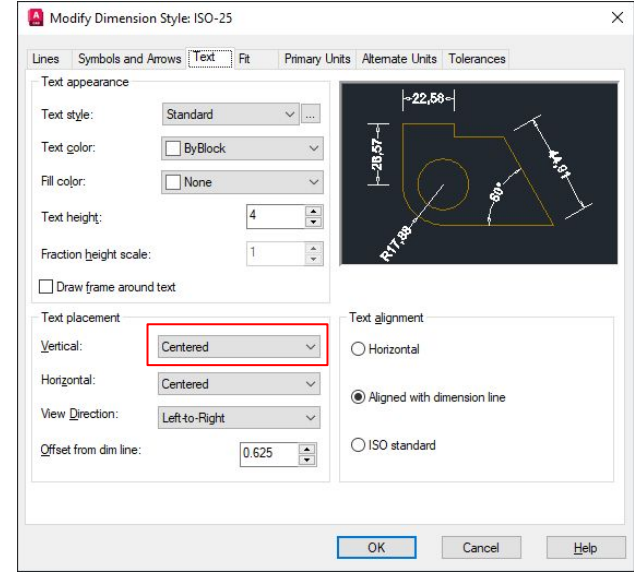
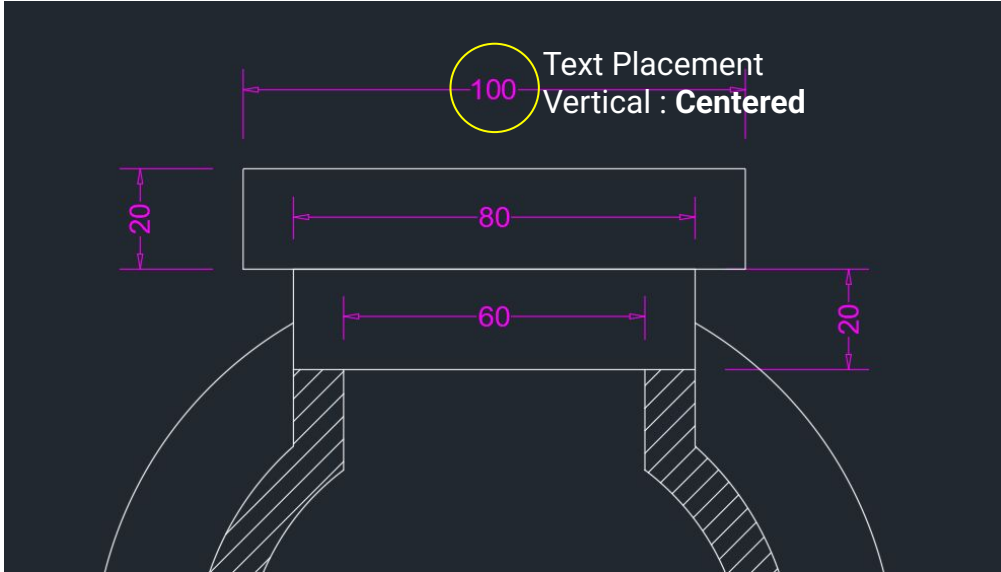

Module 2 Dimension Style - Text

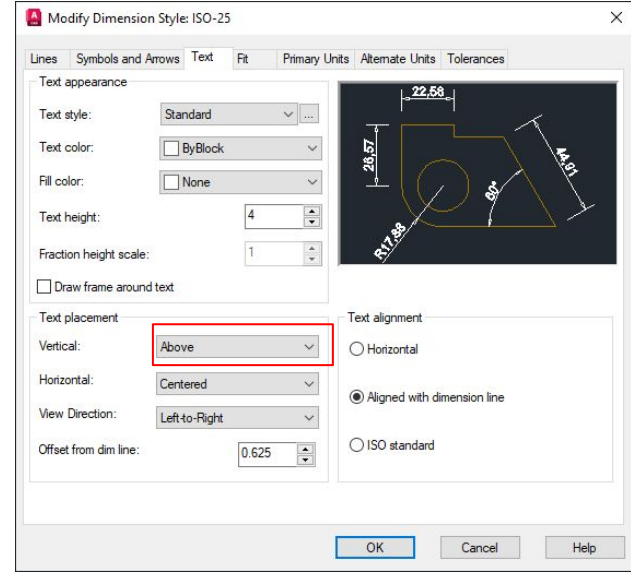
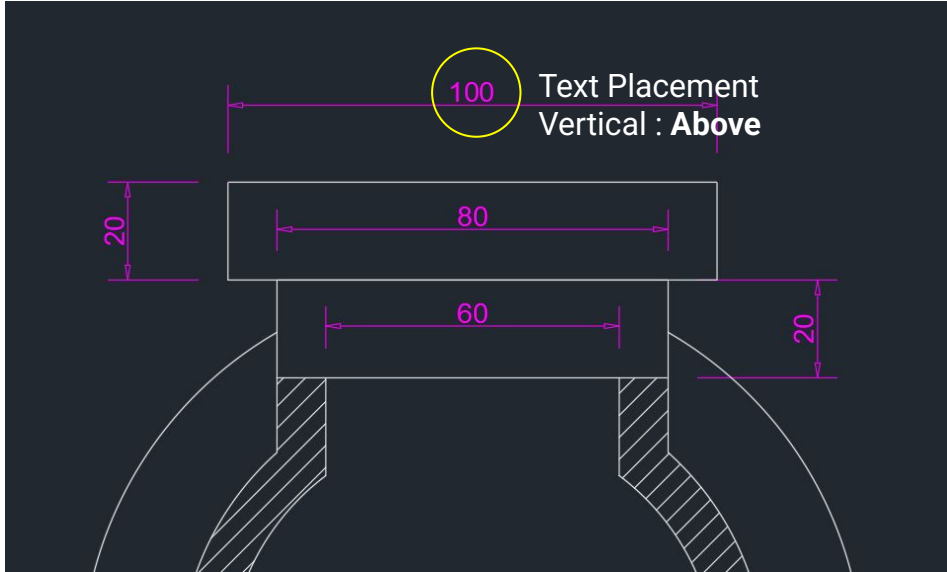

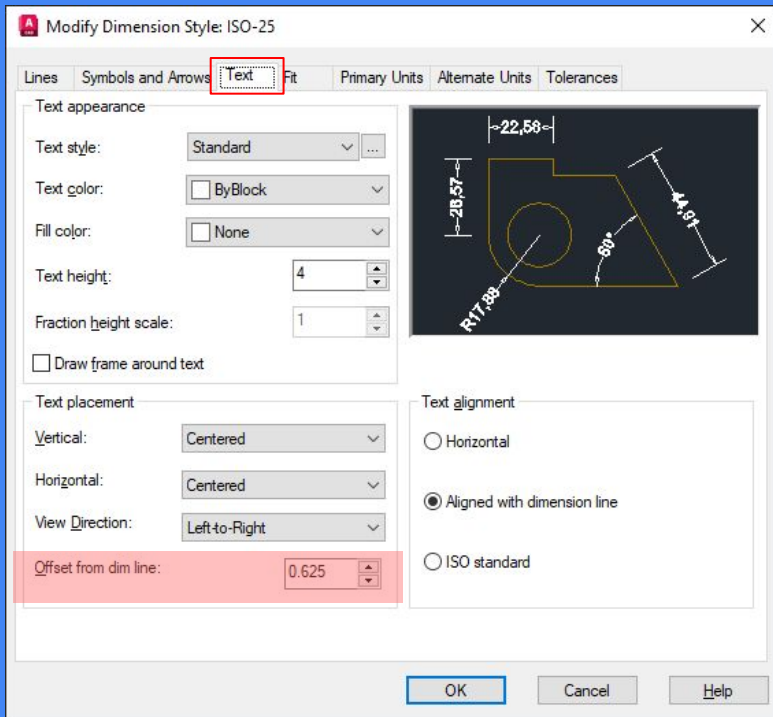

Dimension Style - Text

Text Placement - Offset From Dim Line

Offset From Dim Line refers to positioning text at a specified distance from the dimension line. This ensures that the text does not overlap the dimension line or arrows, improving readability and clarity in the drawing.

Module 2 Dimension Style - Text

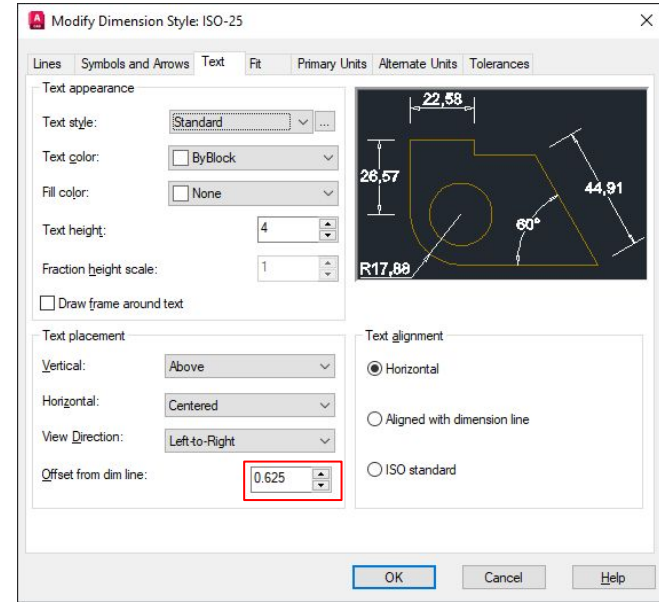
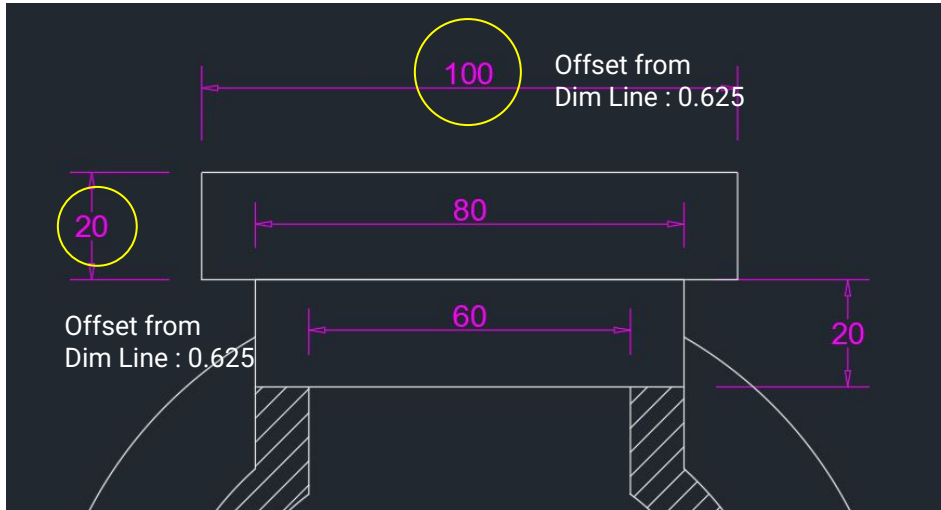

Module 2 Dimension Style - Text

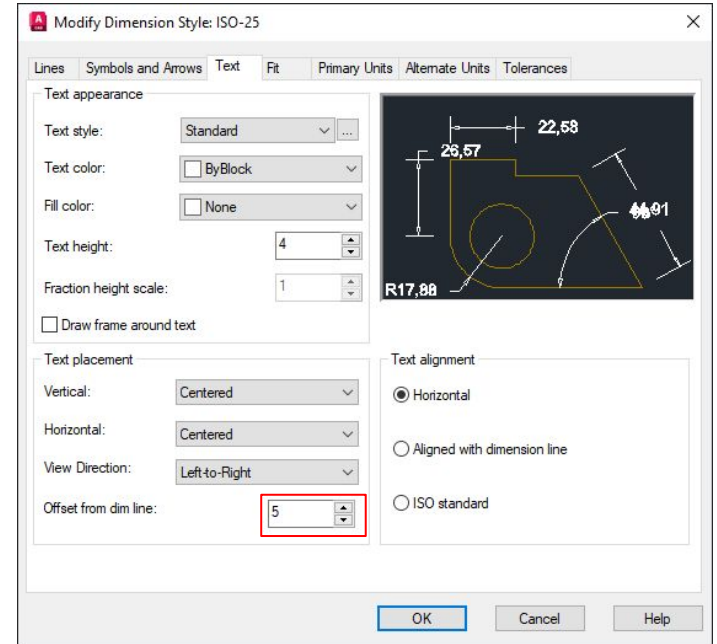
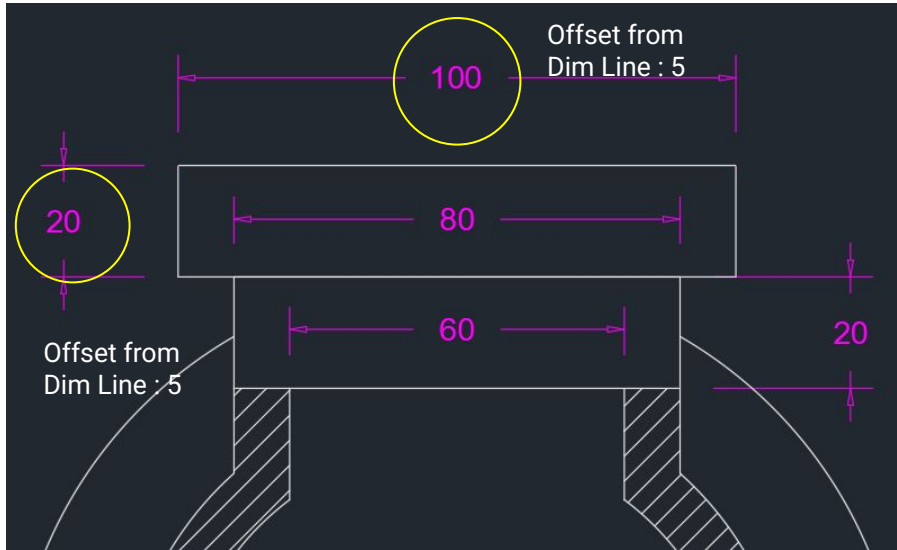

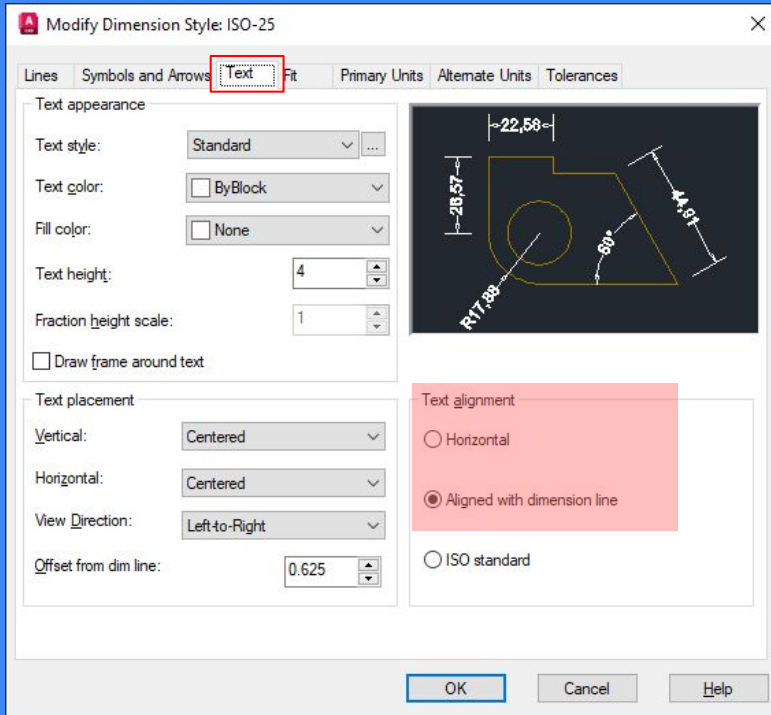

Dimension Style - Text

Text Alignment

Text Alignment refer to the text position is align horizontally or align with drawing line

Module 2 Dimension Style - Text

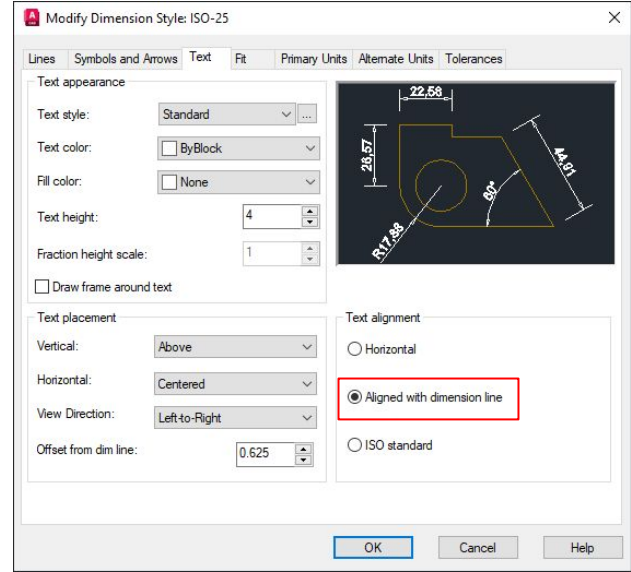
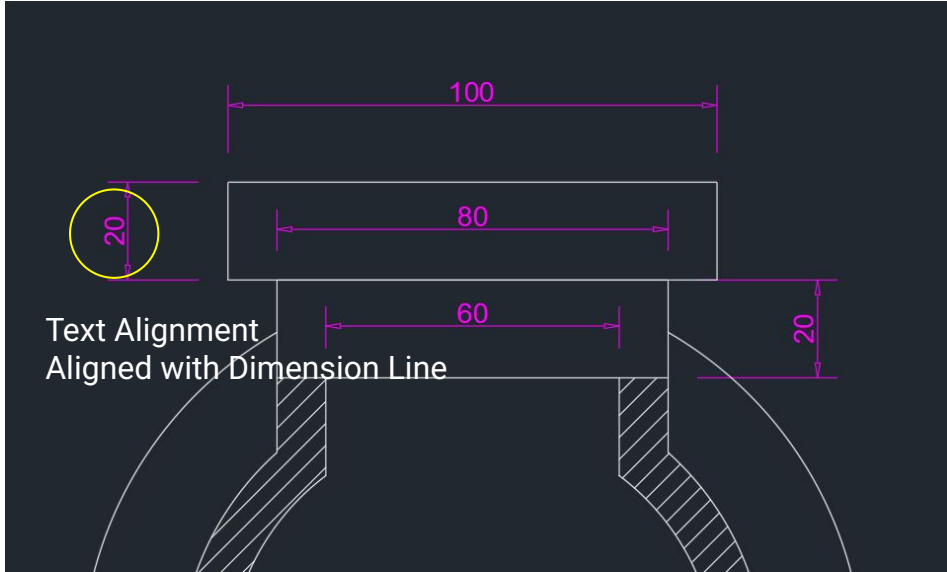

Module 2 Dimension Style - Text

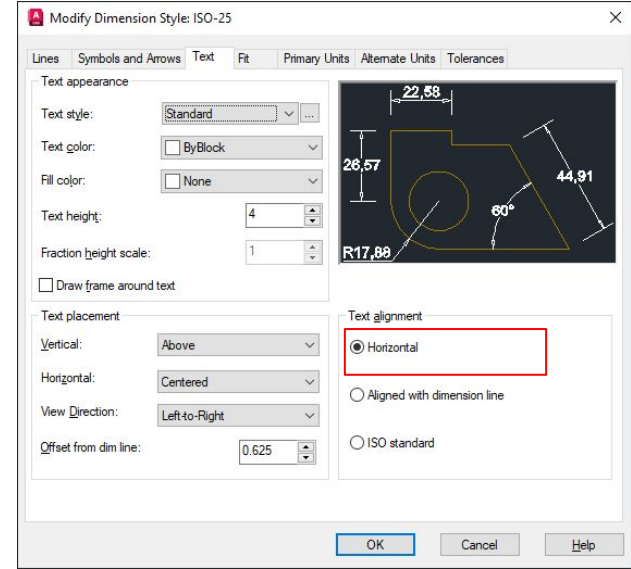
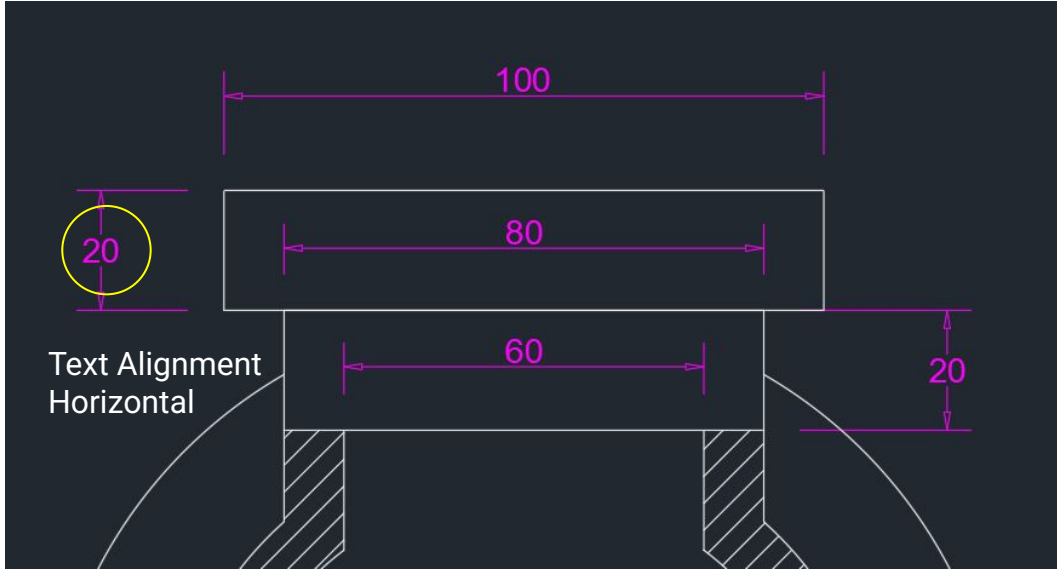

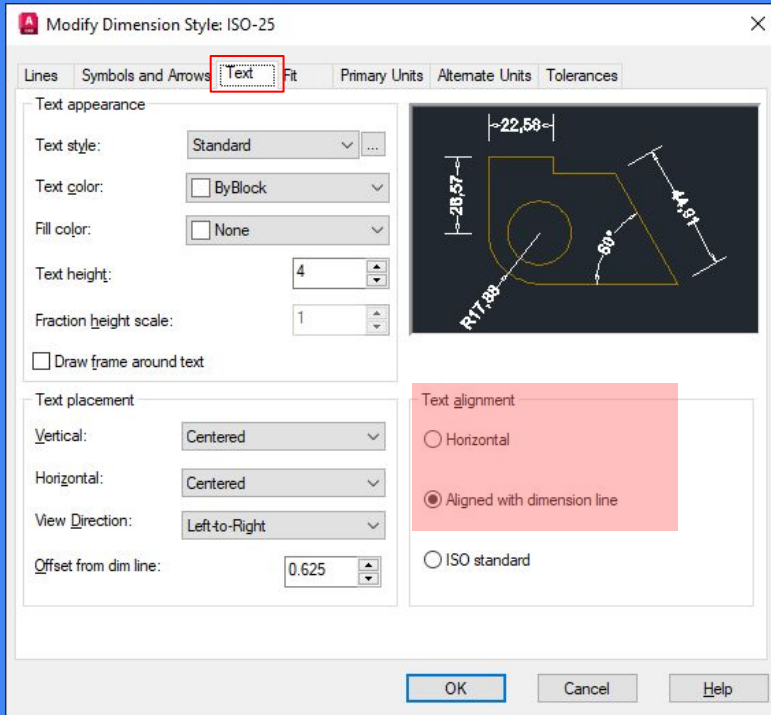

Dimension Style - Line

Text Alignment

Text Alignment refer to the text position is align horizontally or align with drawing line

Module 1

Part 3



Module 2 Array

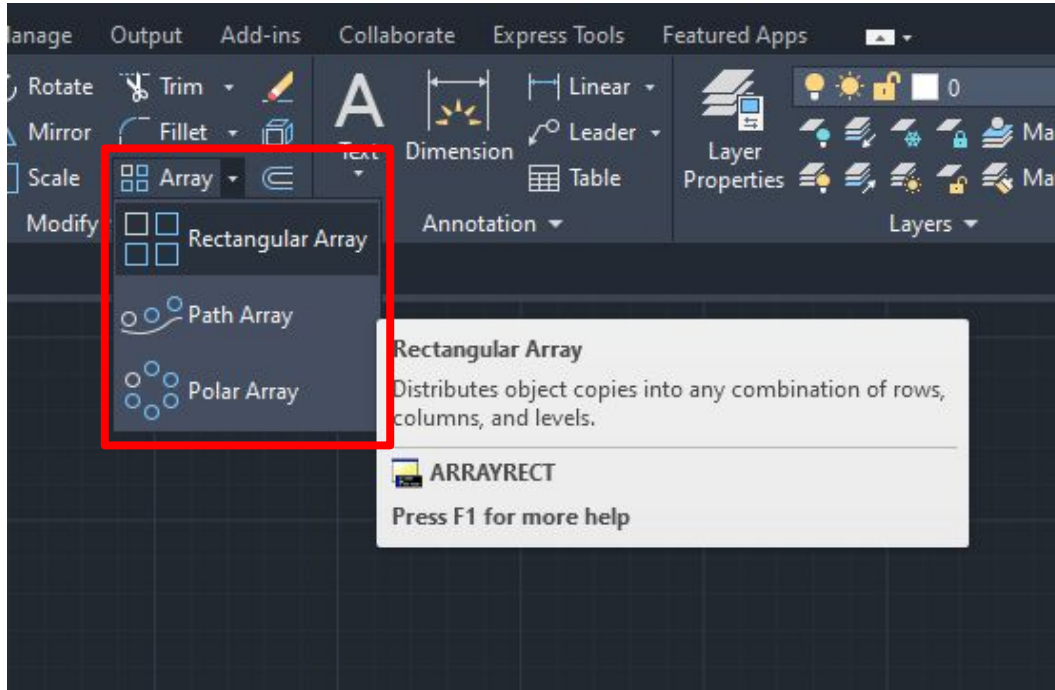

In AutoCAD, an **ARRAY** refers to a feature that allows you to create multiple copies of one or more objects in a specific pattern or arrangement. Arrays are used to efficiently replicate objects in a design, whether it's for creating repetitive elements like columns, windows, or bolts, or for arranging objects in a grid or circular pattern.



Module 1

Exercise 6



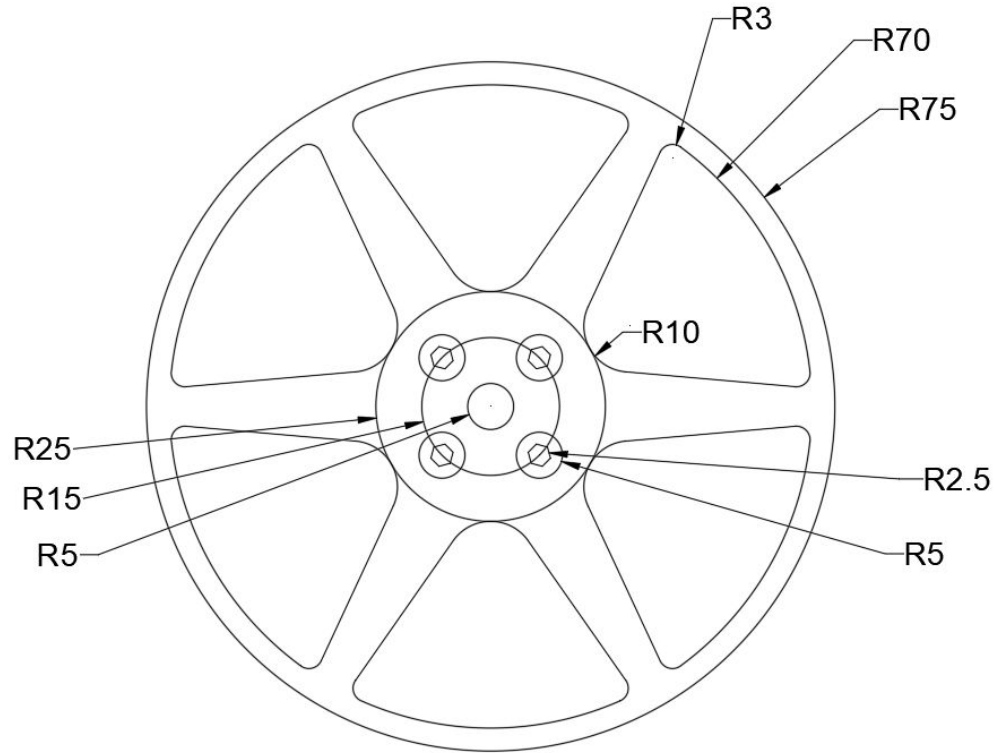

What will you learn?

1. Polar Array
2. Polygon Shape

ARRAYPO

Module 2 Polar Array

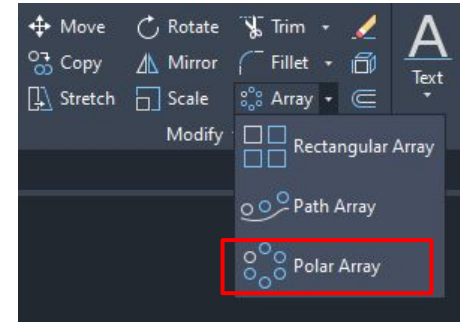
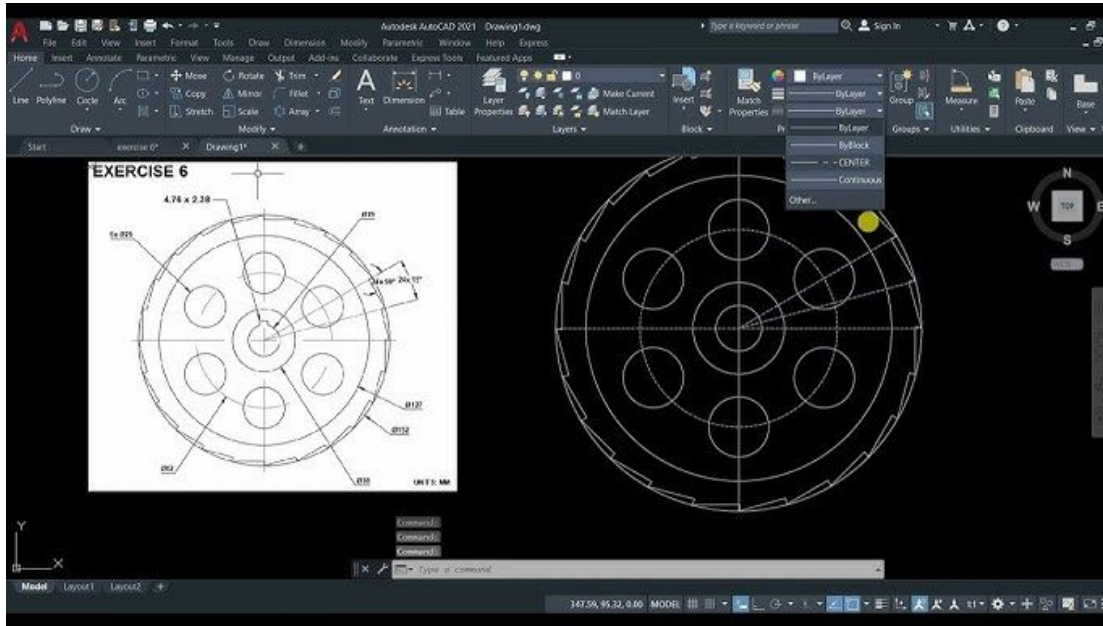

Polar Array `ARRAYP` in AutoCAD is a feature that allows you to create multiple copies of an object arranged in a circular pattern around a specified center point.

Module 2 Polar Array Setting

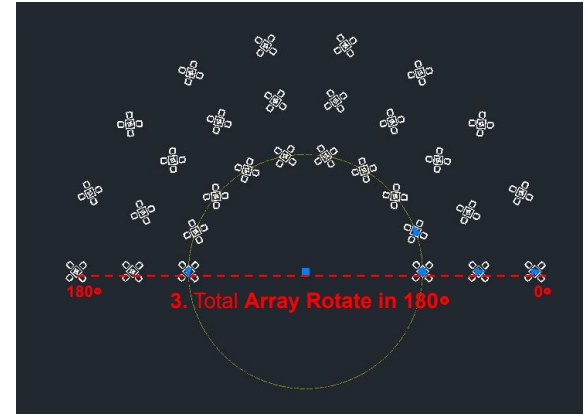
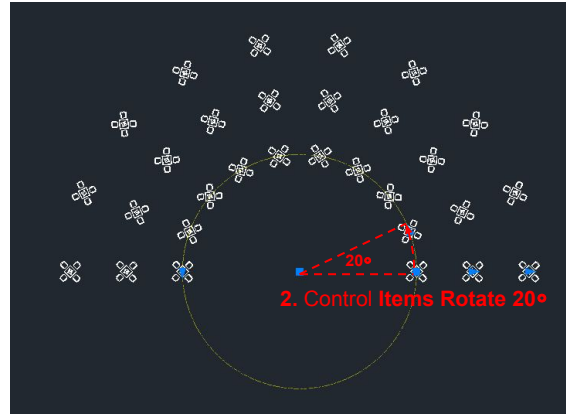
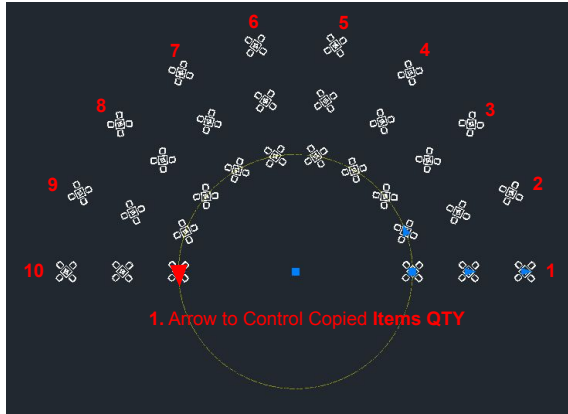

Polar Type	1	Items: 10	Rows: 3	Levels: 1	Associative Base Point Rotate Items Direction Close Array Close
	2	Between: 20	Between: 2000	Between: 1	
	3	Fill: 180	Total: 4000	Total: 1	
		Items	Rows ▾	Levels	Properties

Module 2 Polar Array Setting

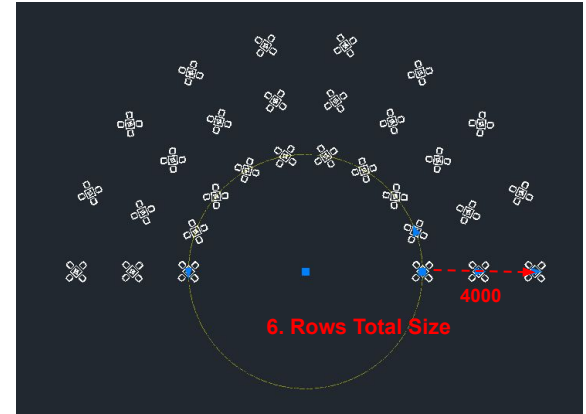
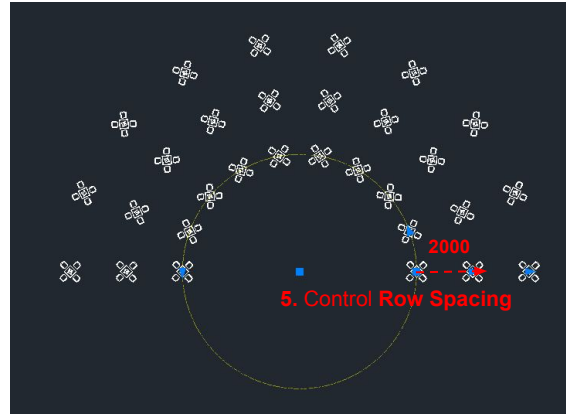
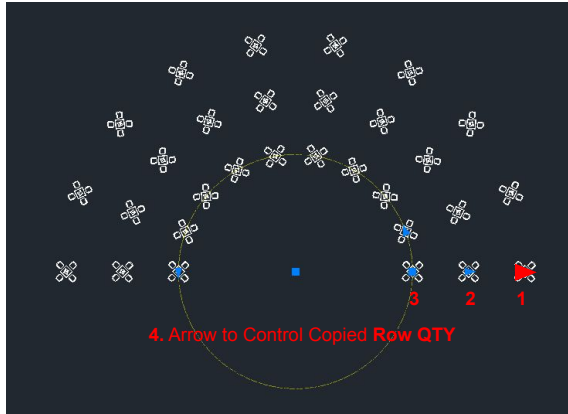

Polar	Items:	10	Rows:	4	3	Levels:	1	Associative	Base Point	Rotate Items	Direction	Close Array	
	Between:	20	Between:	5	2000		Between:						1
	Fill:	180	Total:	6	4000		Total:						1
Type	Items	Rows	Levels	Properties	Close								

Module 2 Polar Array Setting

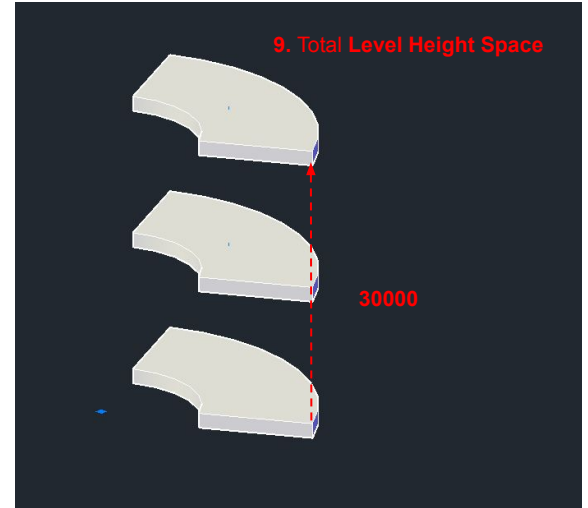
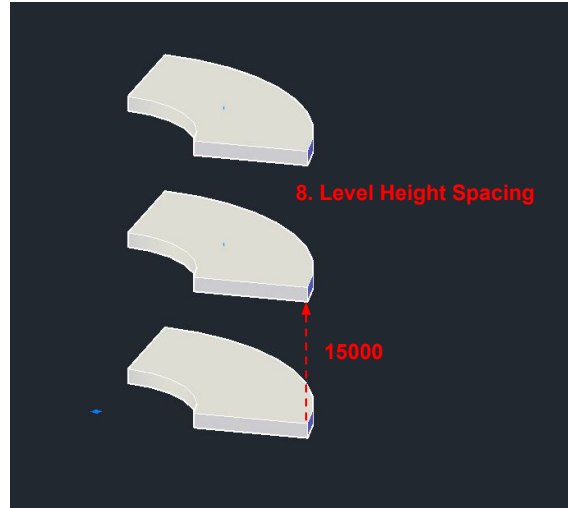

Polar Type	Items: 1	Rows: 1	Levels: 7 3	Associative Base Point Rotate Items Direction Close Array Close
	Between: 360	Between: 5000	Between: 15000	
	Fill: 360	Total: 5000	Total: 30000	
	Items	Rows	Levels	Properties

Module 2 Polygon

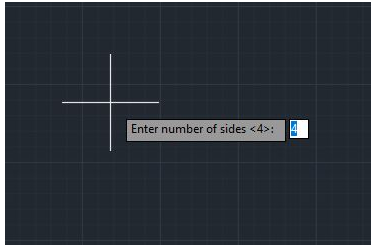
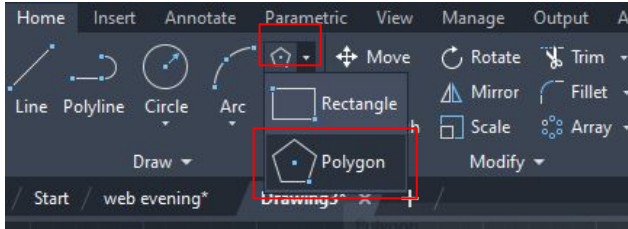

1st Step to Keyin the Polygon Side

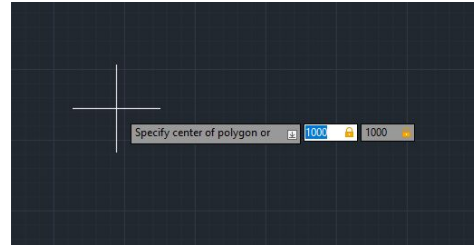

2nd Click to Confirm the Polygon Location

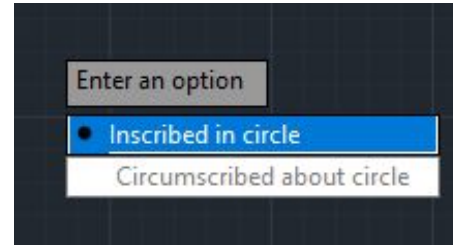

3rd Click to Choose the Options

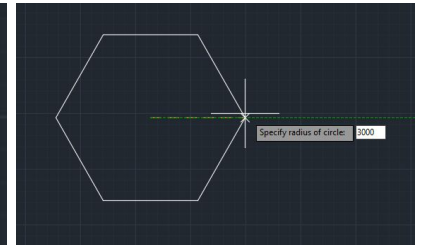

4th Step to Keyin the Polygon Size

Types of Polygons



Triangle
3 sides



Square
4 sides



Pentagon
5 sides



Hexagon
6 sides



Heptagon
7 sides



Octagon
8 sides



Nonagon
9 sides



Decagon
10 sides



Hendecagon
11 sides



Dodecagon
12 sides

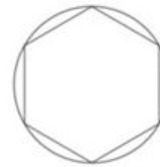

Inscribed

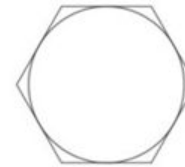

Circumscribed

Module 1

Exercise 7



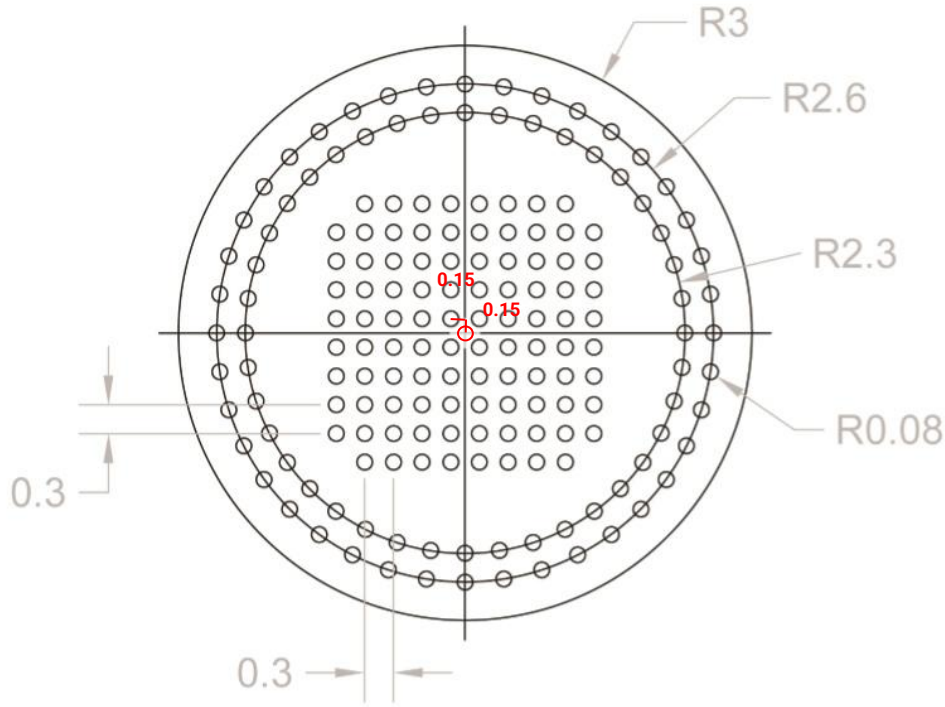

What will you learn?

1. Rectangular Array **ARRAY**

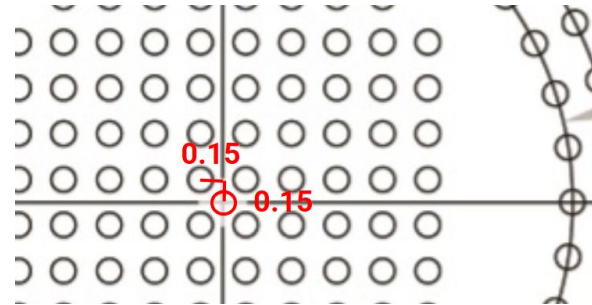

Module 2 Rectangular Array Setting

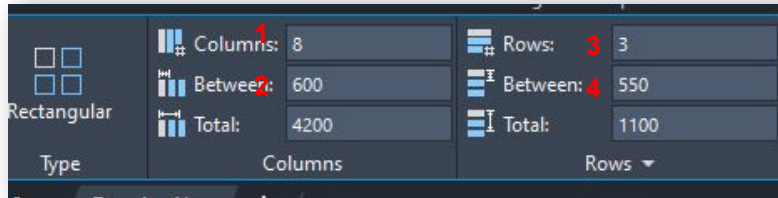
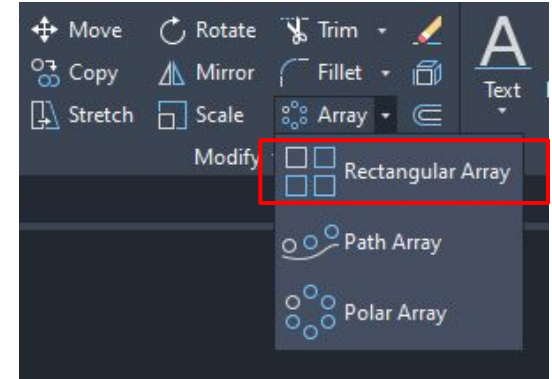
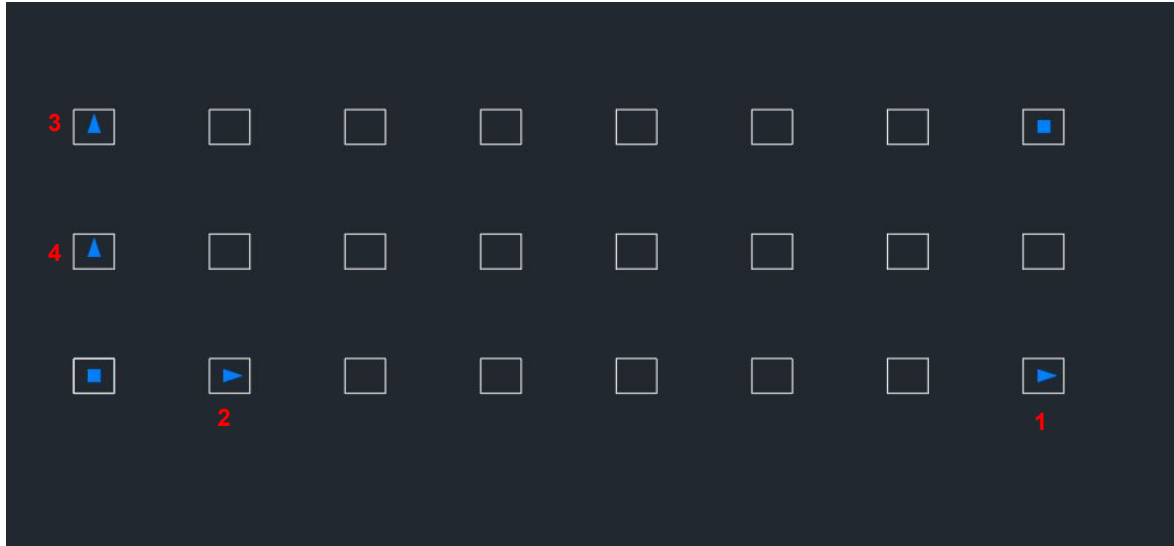

Rectangular Array ARRAY is a command that allows you to create multiple copies of objects arranged in a grid pattern, defined by specified rows and columns with consistent spacing between them.

1. Arrow to control COL Items QTY
2. Arrow to control COL Spacing
3. Arrow to control ROW Items QTY
4. Arrow to control ROW Spacing

AutoCAD

Task 2



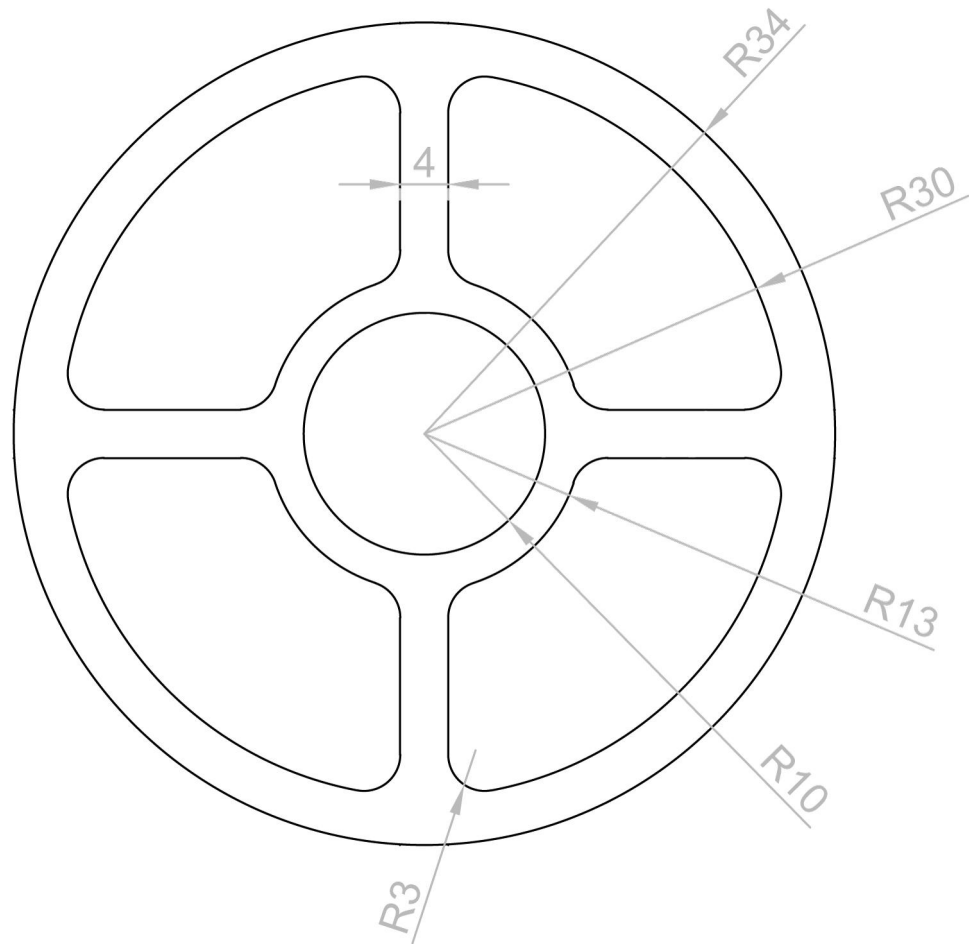

Module 2



Module 2 Offset

Offset OFF command creates parallel lines or curves at a specified distance from the original object. You select the object, specify the offset distance, and the software generates a new, parallel version. This tool is useful for creating features like walls, boundaries, or spacing between elements in a design.

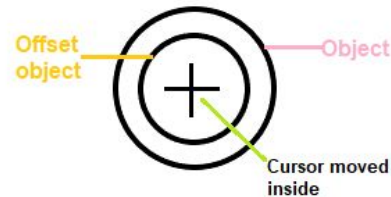
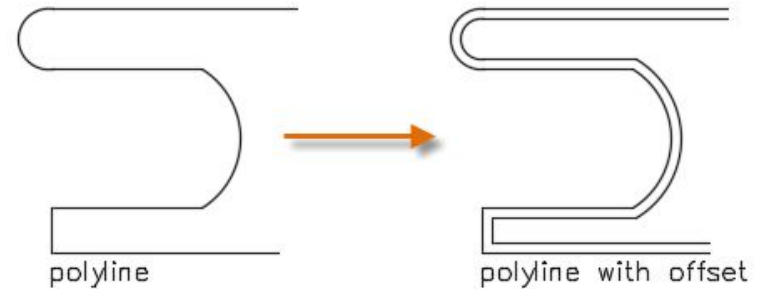
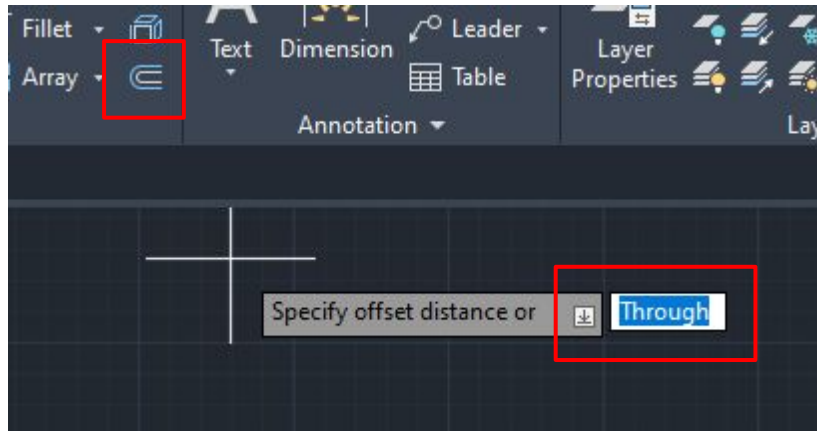

Shrink inwards

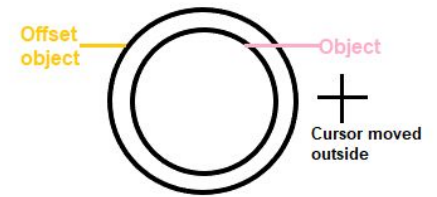

Expand outward

Module 2

Exercise 1



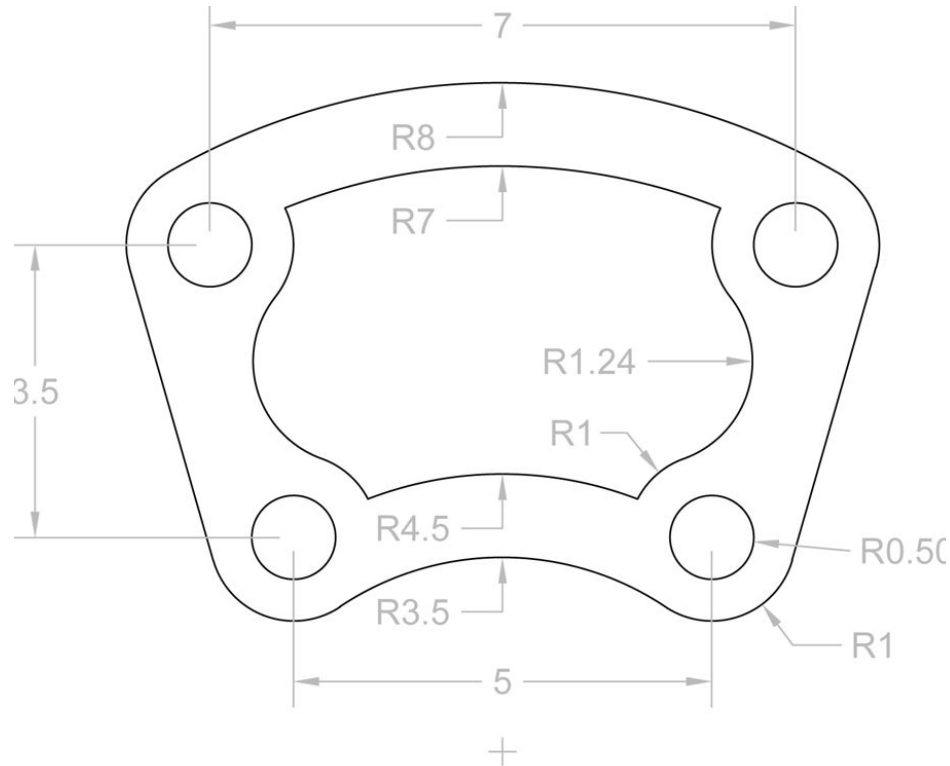

What will you learn?

1. Tangent Radius
2. Tangent Line
3. Offset

LIN

OFF

AutoCAD

Task 3



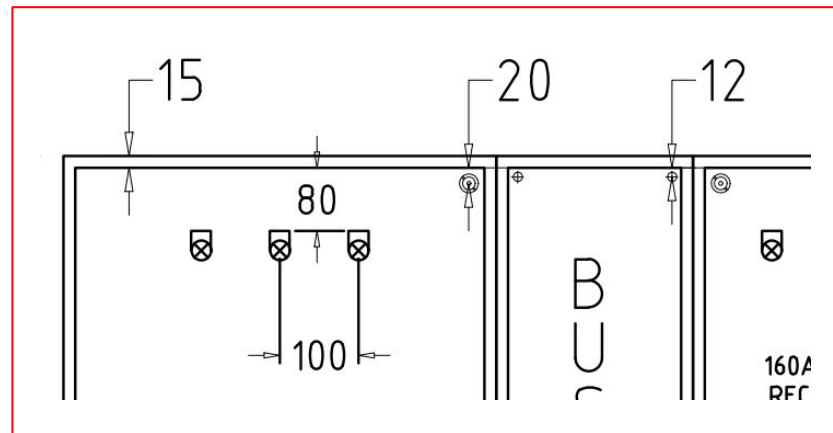
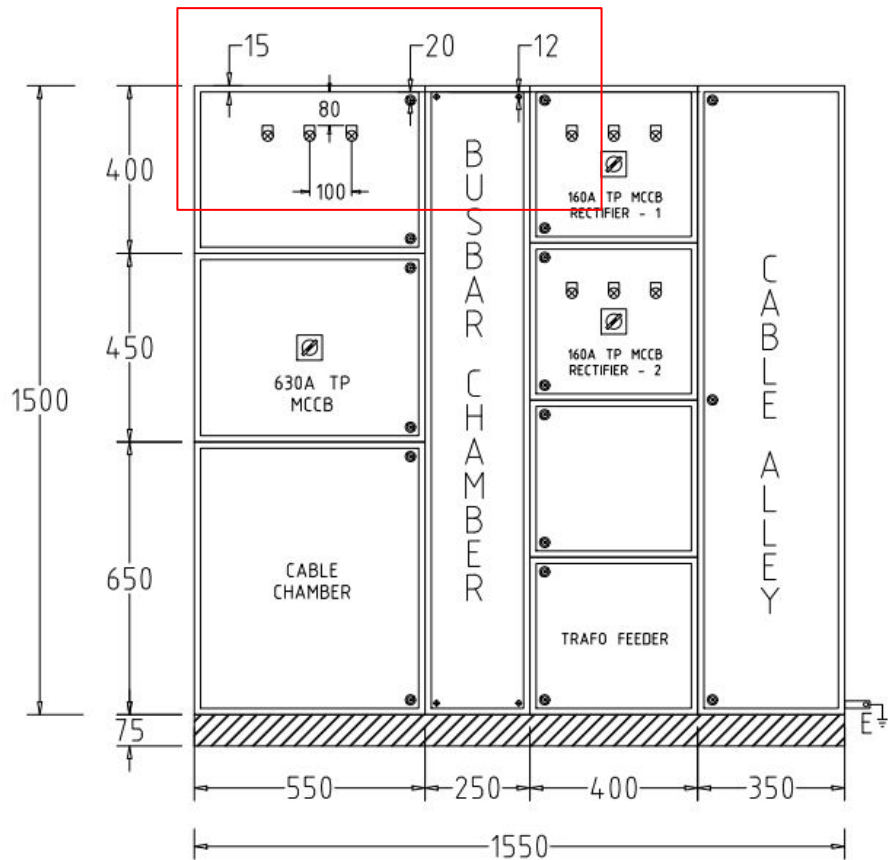

SWITCHGEAR

Text & Text Property

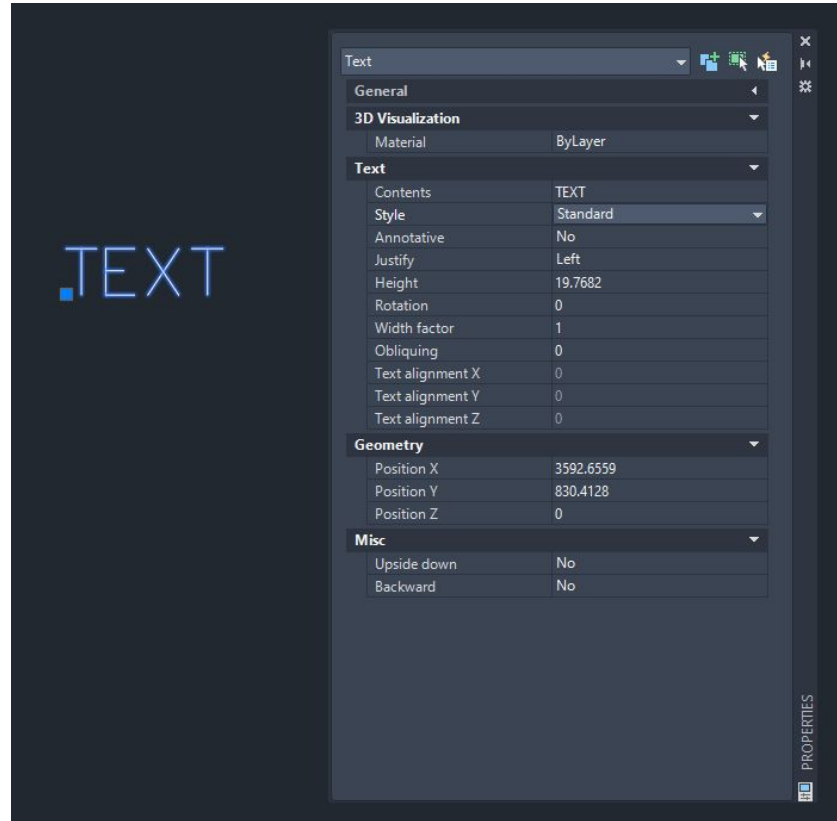

Text & Text Property

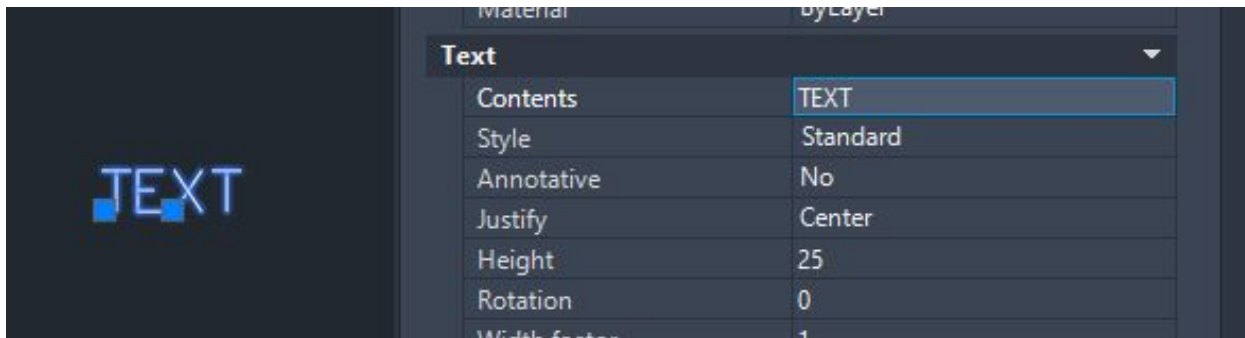

Text & Text Property

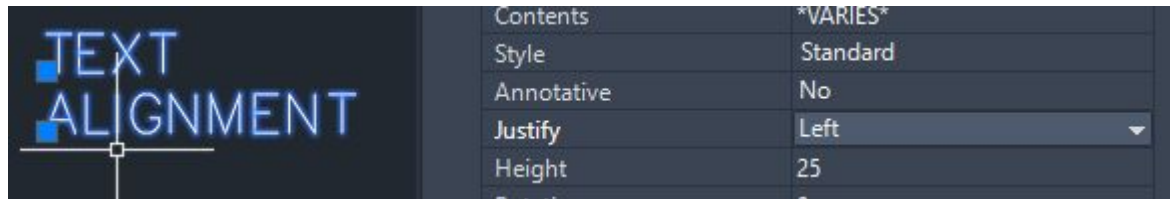
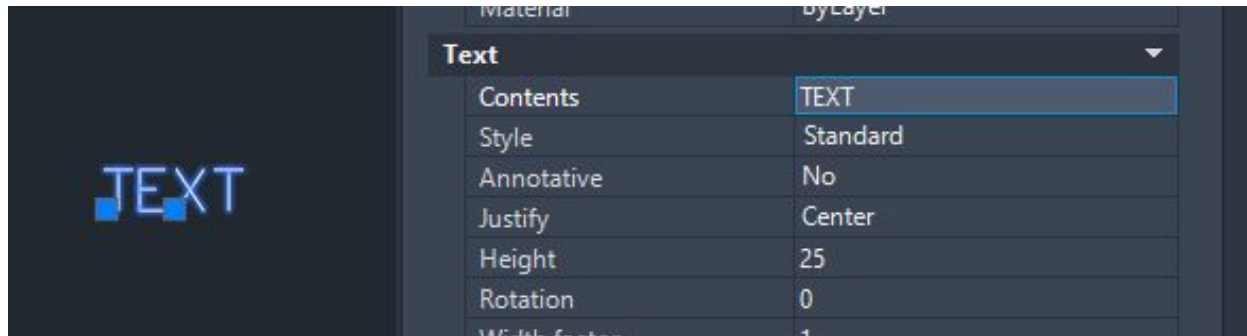

Module 2 Text Style

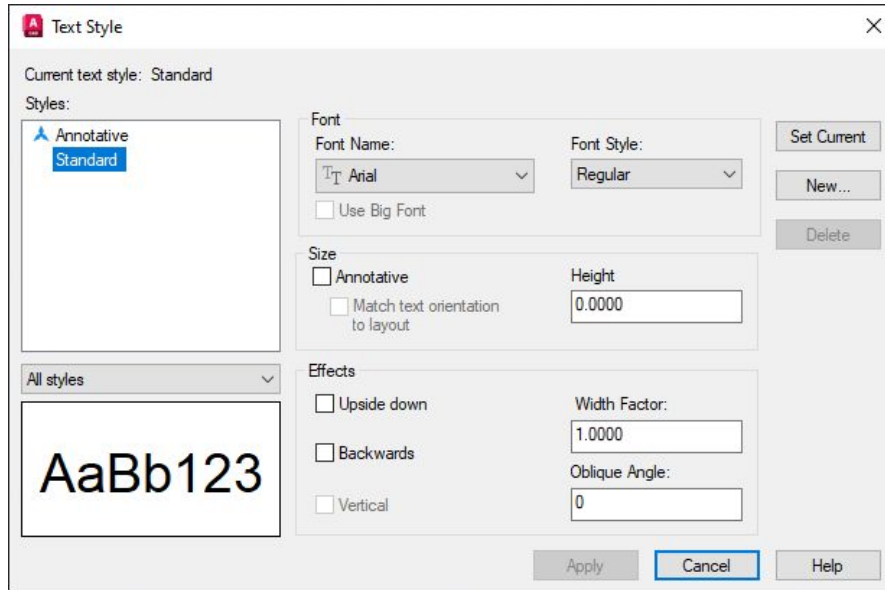

Text Style STY defines the appearance of text, including font type, size, height, width, and other formatting options. By managing text styles, you can ensure consistency and improve readability in your drawings. Text styles can be easily applied to different text objects for quick adjustments.

Important Points

- | | |
|----------------------|---------------|
| 1. Hatch | HAT |
| 2. Dimension Style | DIMST |
| 3. Polar Array | ARRAYP |
| 4. Rectangular Array | ARRAY |
| 5. Text Style | ST |
| 6. Offset | OFF |



Module 3



Our Lesson - Module 3

- 1. Mastering the Art of Layers**
understanding layers is a fundamental skill. Layers enable you to organize and control the visibility of your drawing elements in your designs
- 2. Crafting Efficiency: Creating Blocks**
Blocks allow you to efficiently reuse and manage design components and maintaining consistency throughout your projects.
- 3. Perfecting Your Presentation: Layout View Setup**
Elevate your drawing presentation by delving into the art of layout view setup to ensure your designs are presented with the professionalism they deserve.
- 4. Multiplying Perspectives: Public Multiple Layout Views**
This feature lets you convey your design from various perspectives, enhancing communication and visualization for a more comprehensive design experience.
- 5. Data in Style: Tables**
Tables are your key to effectively presenting data in AutoCAD. Whether you're managing information in architectural drawings, charts, or schedules, tables ensure that your data is organized and visually appealing.

DOWNLOADING AUTOCAD BLOCK FROM THE INTERNET CAN LEAD TO VARIOUS ISSUES.

1. **Inconsistent Block Sizes:** Blocks may exhibit varying sizes, leading to inconsistencies in your drawings, with some appearing too large and others too small.
2. **Color Discrepancies:** Differences in color can arise, causing disruptions in the visual cohesion of your designs when incorporating downloaded blocks into your AutoCAD projects.
3. **Unnecessary and Peculiar Layers:** Extraneous and unconventional layers may be included in downloaded blocks, introducing complexity and clutter to your drawing environment.

Module 3

Exercises



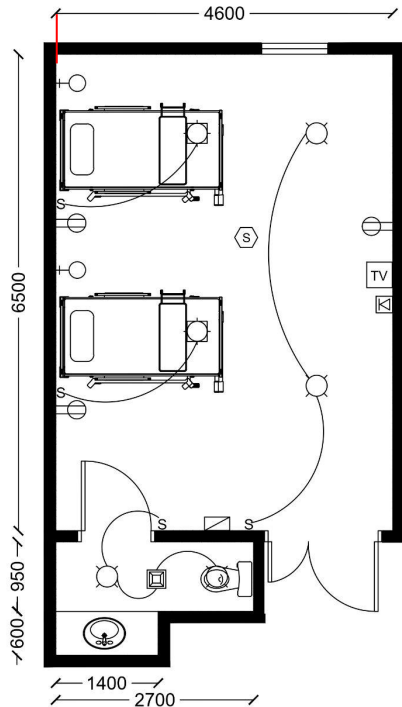

Hospital Ward M&E Table

Description		Count
	Ceiling Mounted Light	4
	Ceiling Ventilator	1
	Duplex Receptacle Outlet	3
	Emergency Light	1
	Nurse Call	2
	Recessed Down Light	2
	Smoke Detector	1
	Switch	4
	Telephone Outlet	1
	TV Outlet	1

What will you learn?

1. Drawing Limit
2. Layer
3. Block
4. Count List
5. Property
6. Layout Configuration
7. View Port

LIM

LA

B

COUNT

PR

PAGE

VPO

Module 3 Model Phase

- 
- Step 1** — **Drawing Limit**
Confirm the drawing area size of the workspace for the drawing
 - Step 2** — **Wall Creation**
Use Polyline start the wall drawing, and offset the wall thickness
 - Step 3** — **Create Layer**
Create Layer for Dimension, Furniture & M&E
 - Step 4** — **Dimension**
Insert the drawing measurement
 - Step 5** — **Import Block**
Download the block from internet and solve the problem
 - Step 6** — **Custom Block**
Create Custom Block for Door, window and M&E Items

Module 3 Drawing Limit

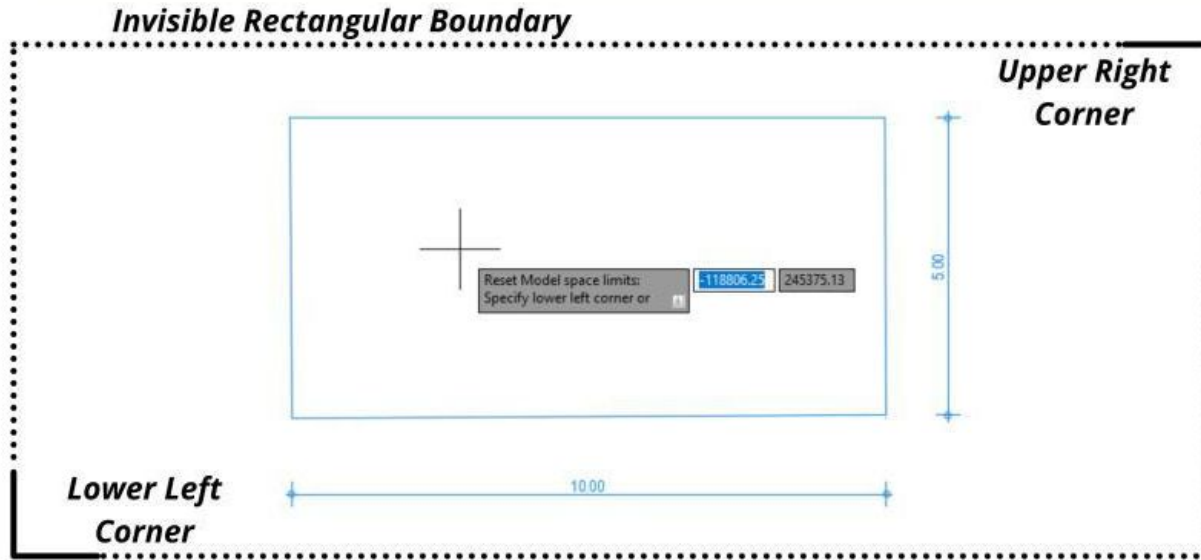

The **Drawing Limit LIM** refers to the boundary or size of the workspace within which you can draw. The drawing limits help guide the scale of your work but don't restrict where you can actually draw

Module 3 Drawing Limit Sample 1

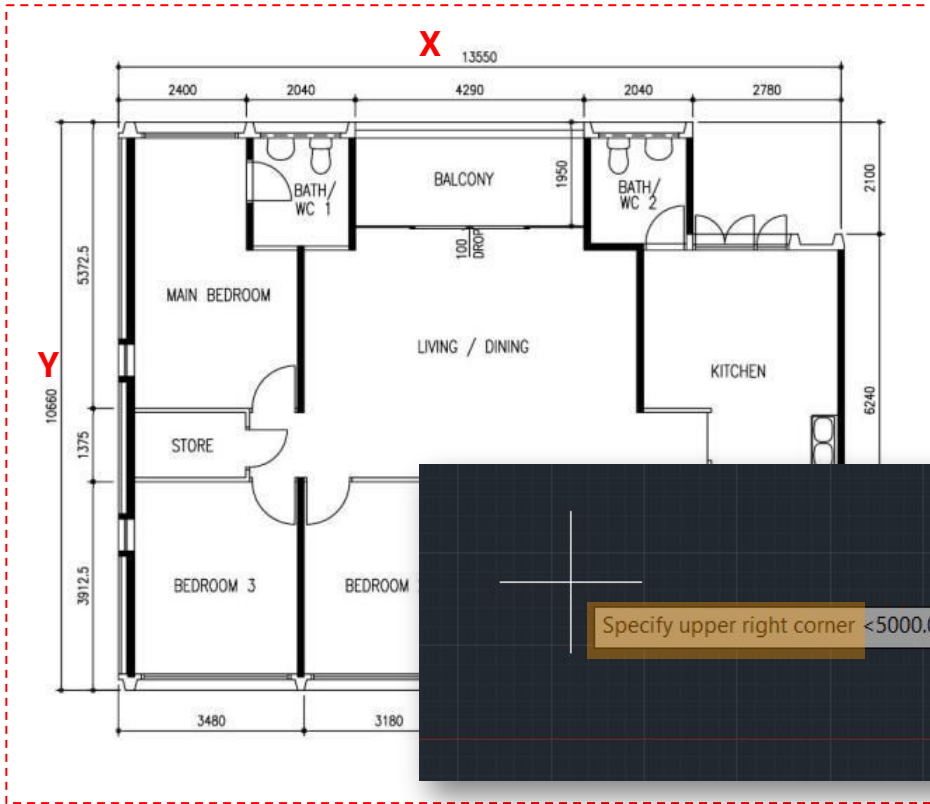

Specify upper right corner <5000.0000,9000.0000>: 15000 12000

The interface shows a dark grid background with a white crosshair. The command line is highlighted in a light brown box. To the right of the command line, there are two input fields: the first contains '15000' and the second contains '12000'. A red 'X' is positioned below the first field, and a red 'Y' is positioned below the second field.

Module 3 Drawing Limit Sample 2

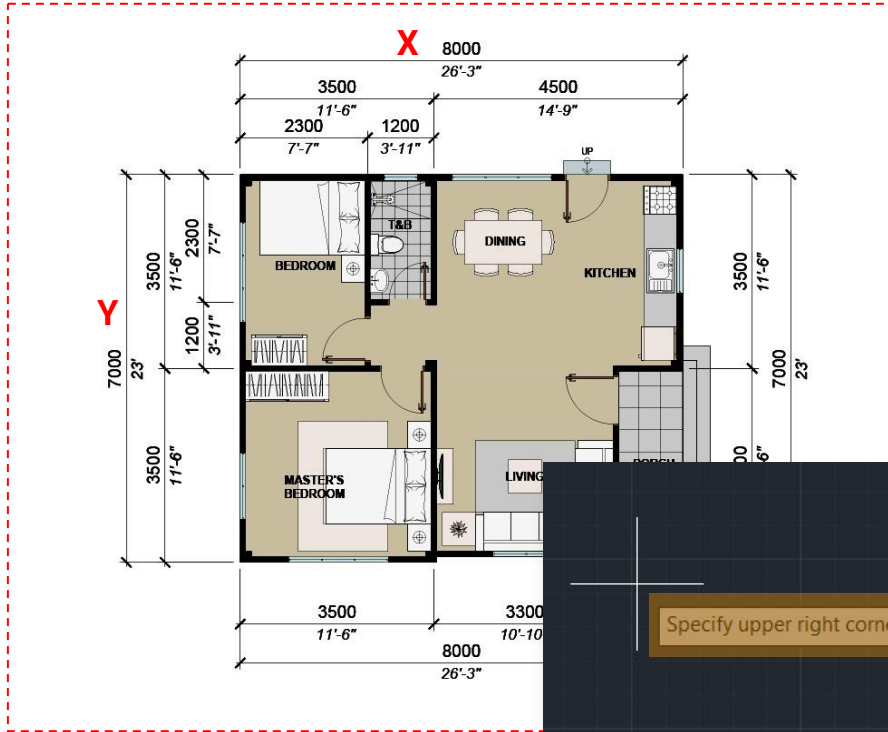

Specify upper right corner <5000.0000,9000.0000>; 10000 10000

X Y

Module 3 Layout Phase

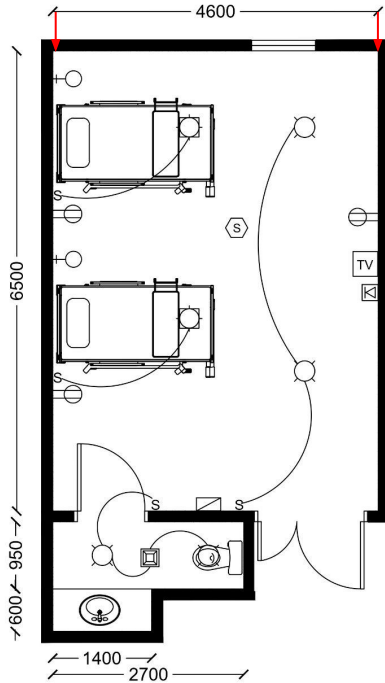

Hospital Ward M&E Table

	Description	Count
	Ceiling Mounted Light	4
	Ceiling Ventilator	1
	Duplex Receptacle Outlet	3
	Emergency Light	1
	Nurse Call	2
	Recessed Down Light	2
	Smoke Detector	1
	Switch	4
	Telephone Outlet	1
	TV Outlet	1

- Step 7 **Layout Configuration**
Setup the output format (PDF) and layout size
- Step 8 **VP Freeze**
Organize the layout items visibility
- Step 9 **Insert M&E Table**
Insert Title and table for M&E Items
- Step 10 **Publish**
Export to PDF

Module 3 Layer Property

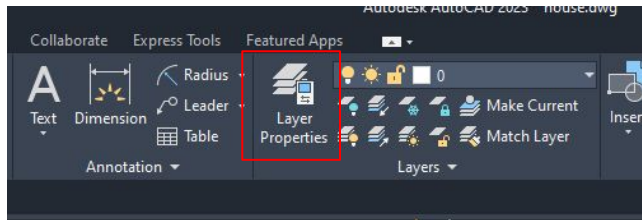

Layer Property LA

Layers play a crucial role in organizing and managing the visual representation of objects in a drawing.

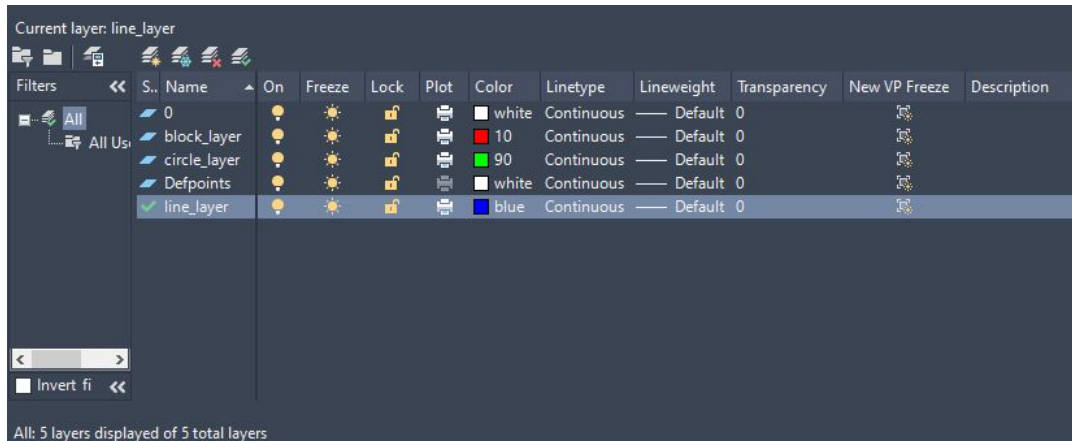

1. Organizing Objects
2. Controlling Visibility
3. Standardized Color and Linetype
4. Isolating and Freezing
5. Plotting and Printing

Module 3.3 Block

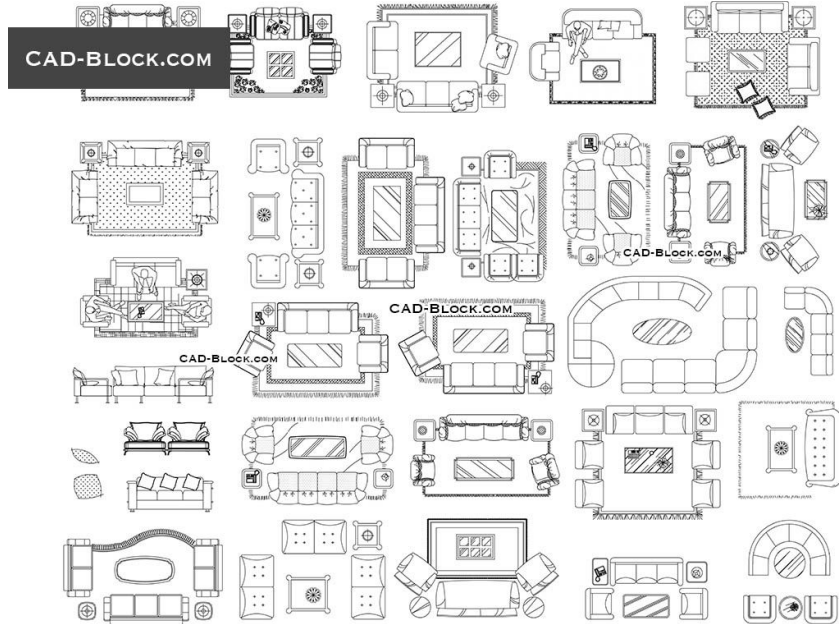

The **Block B** is a collection of objects combined into a single object that can be reused multiple times in a drawing, streamlining the design process and ensuring consistency.

1. **B** Create Block
2. **Blocks** Open Block Library
3. **Purge** Delete Unused Block
4. **Rename** Rename Block Name

Module 3.3 Create Block

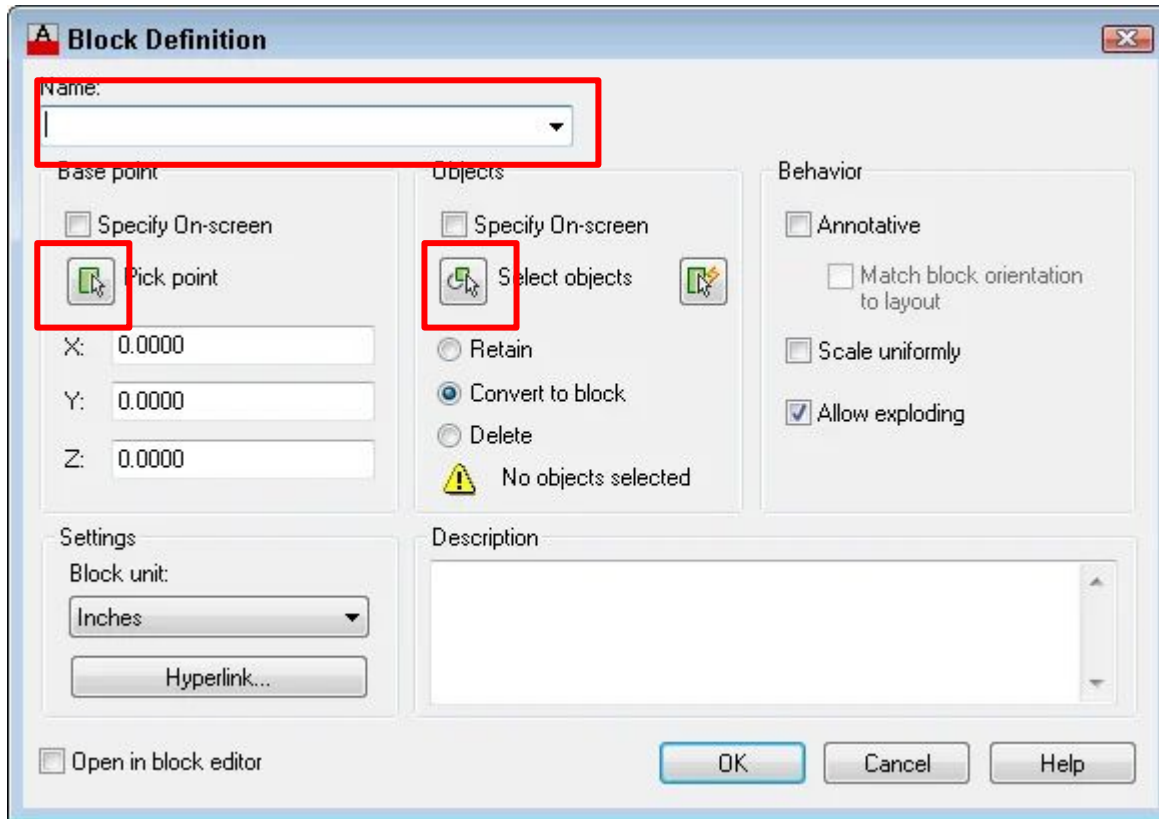

Important Points

1. Name
2. Pick Point
3. Select Object

Module 3.4 Purge Block

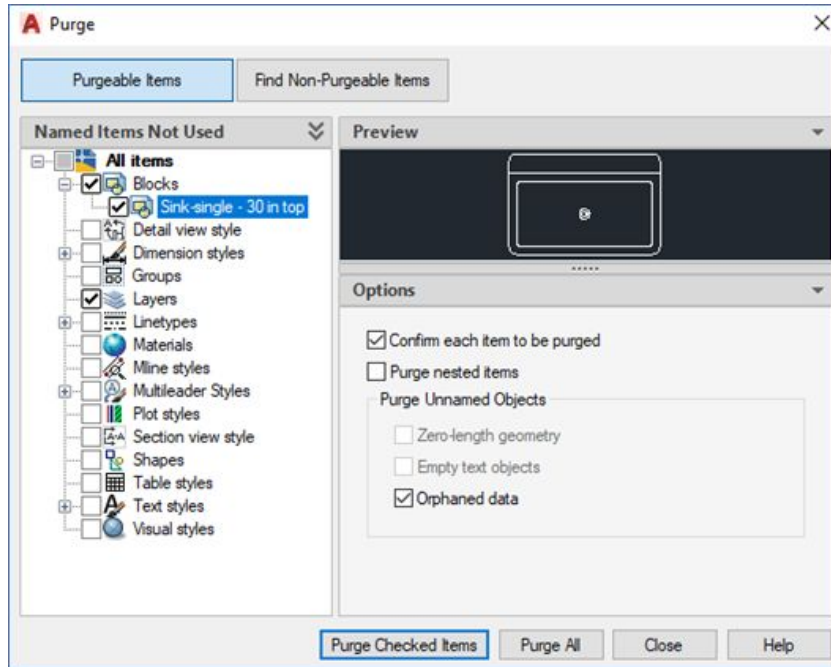

Purge refers to the process of removing unused or unnecessary elements, such as **BLOCKS**, layers, linetypes, and other objects, from a drawing file.

View Port Freeze

Viewport Freeze in AutoCAD allows you to freeze specific layers within a viewport while keeping them visible in others or in model space. This helps manage complex drawings by controlling layer visibility individually, enhancing clarity without affecting the entire drawing.

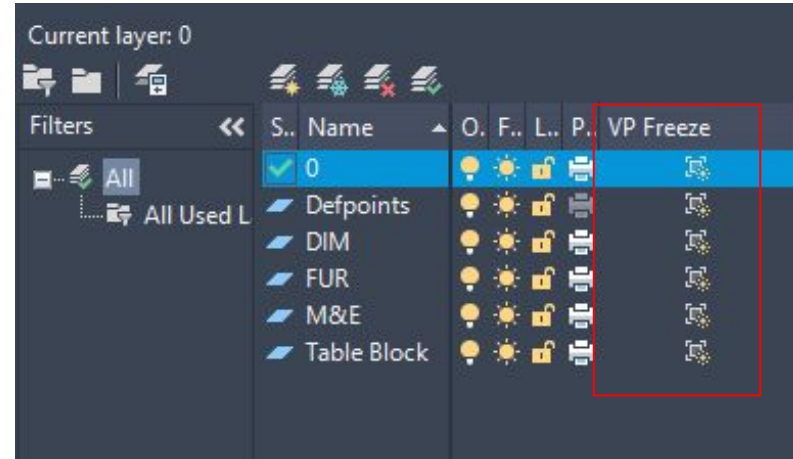

View Port Freeze

Viewport Freeze in AutoCAD allows you to freeze specific layers within a viewport while keeping them visible in others or in model space. This helps manage complex drawings by controlling layer visibility individually, enhancing clarity without affecting the entire drawing.

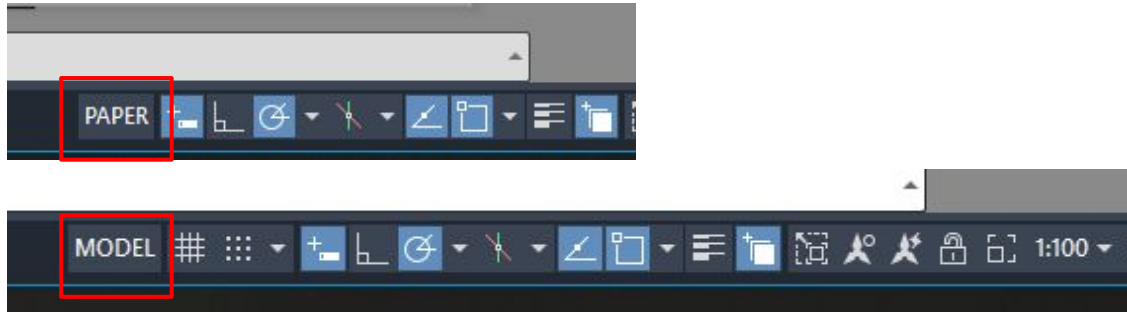

Module 3 Layout Page Setup

Layout Page Setup **PAGE**

Layout **Page Setup PAGE** configures how your drawing will appear when printed. It allows you to select paper size, orientation, and margins, specify the plot area, set the scale, and define plot styles for different objects.

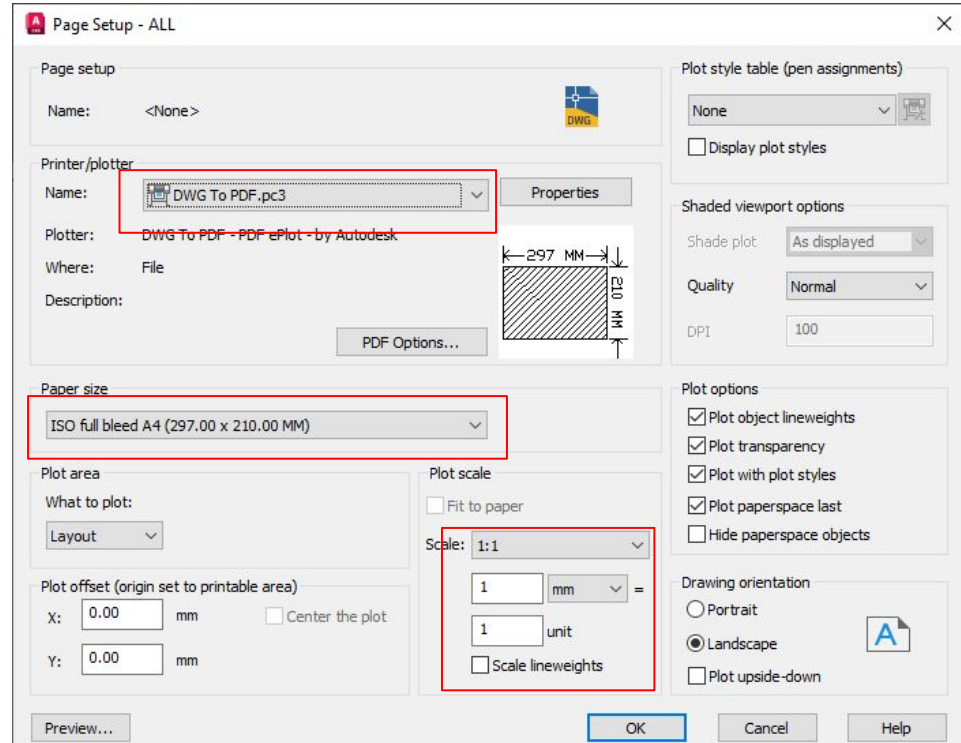
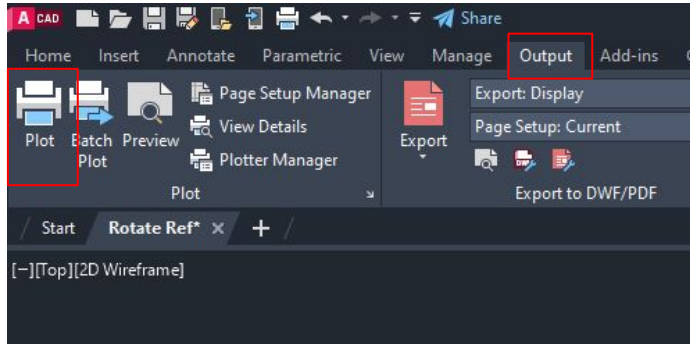

Module 3 Publish

Publish Command PUB

Publish command is used to create a set of plotted or printed drawings. **The Publish command allows you to batch plot multiple layouts or drawings at once,** streamlining the process of creating a set of printed or electronic files.

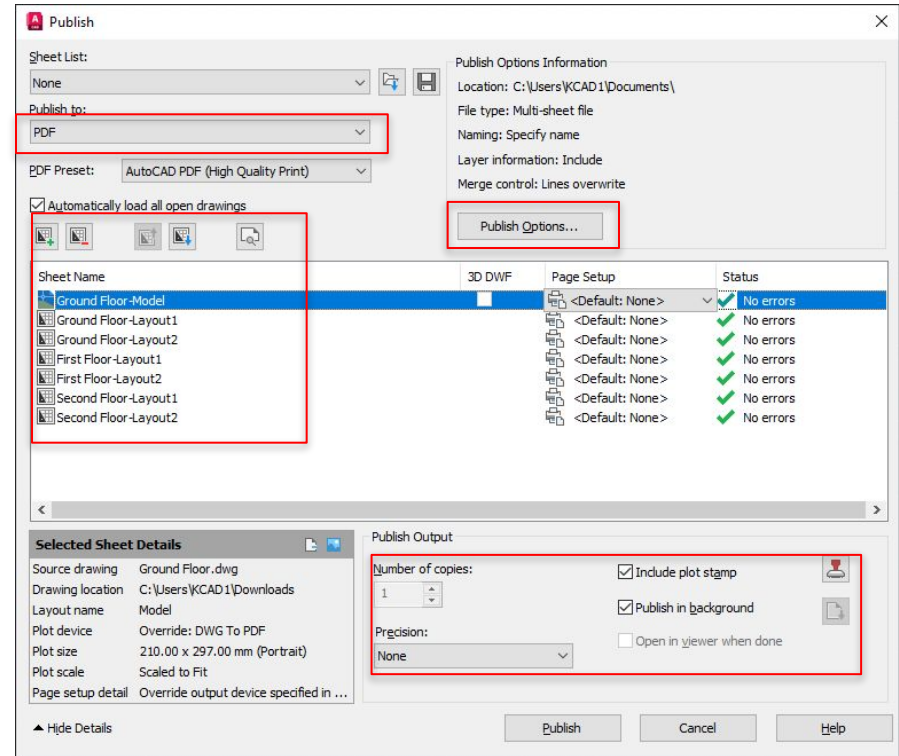
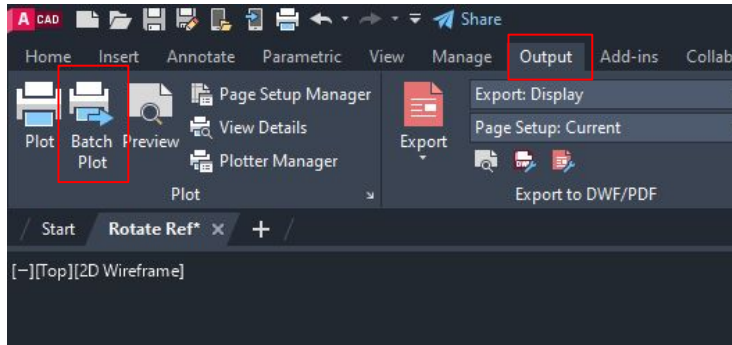

Module 3 Publish Setting

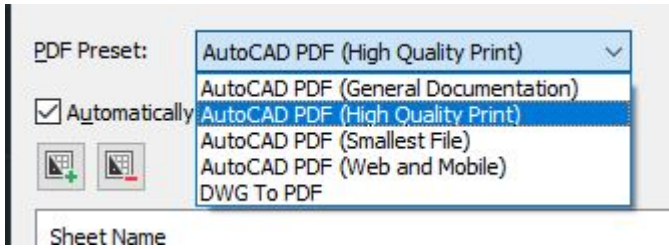

1. **PDF:** Creates a PDF file that can include multiple sheets in one document.
2. **DWF (Design Web Format):** Creates a DWF file, which is a lightweight, secure format often used for sharing drawings online.
3. **Plotter/Printer:** Allows you to publish directly to a physical printer or plotter, based on your selected plotter settings.
4. **Other File Formats:** You might also see options like PostScript, PNG, or other custom plot formats depending on your AutoCAD configuration and available plotters.

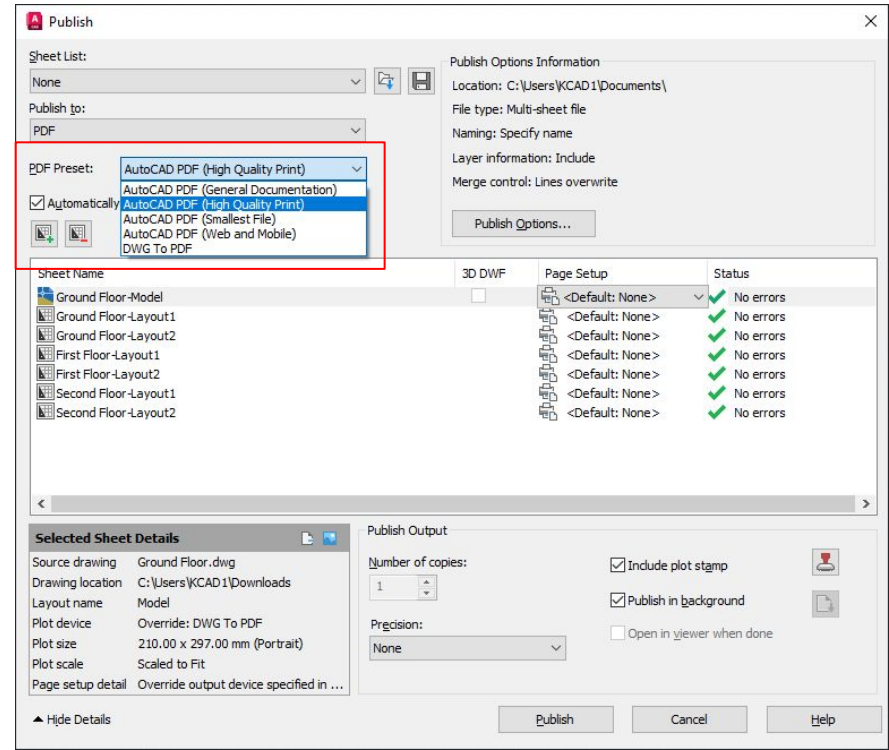

Module 3 Publish Setting

Document Sorting

Automatically load all open drawings



1. Add Other Drawing
2. Remove Model or Layout
3. Move the Document Up
4. Move the Document Down
5. Preview

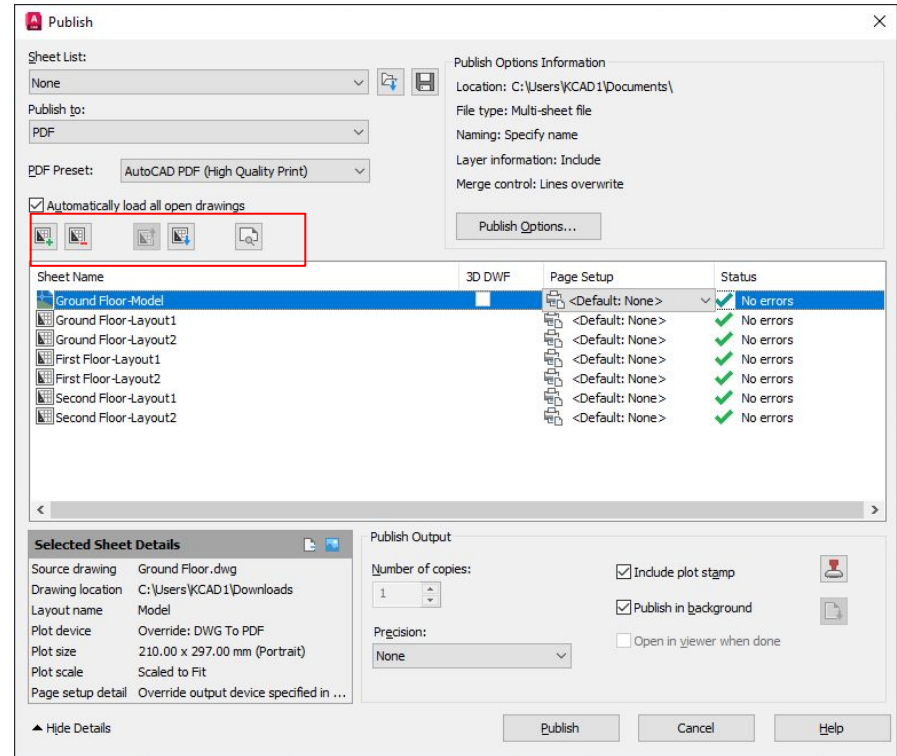

Module 3 Publish Setting

Multi-Sheet File

The "Publish Multi-Sheet PDF" feature in AutoCAD lets you combine multiple layout sheets into a single PDF file, making it easy to share or print an entire drawing set as one document.



PUBLISH



draw1.pdf



draw2.pdf



draw3.pdf



draws.pdf

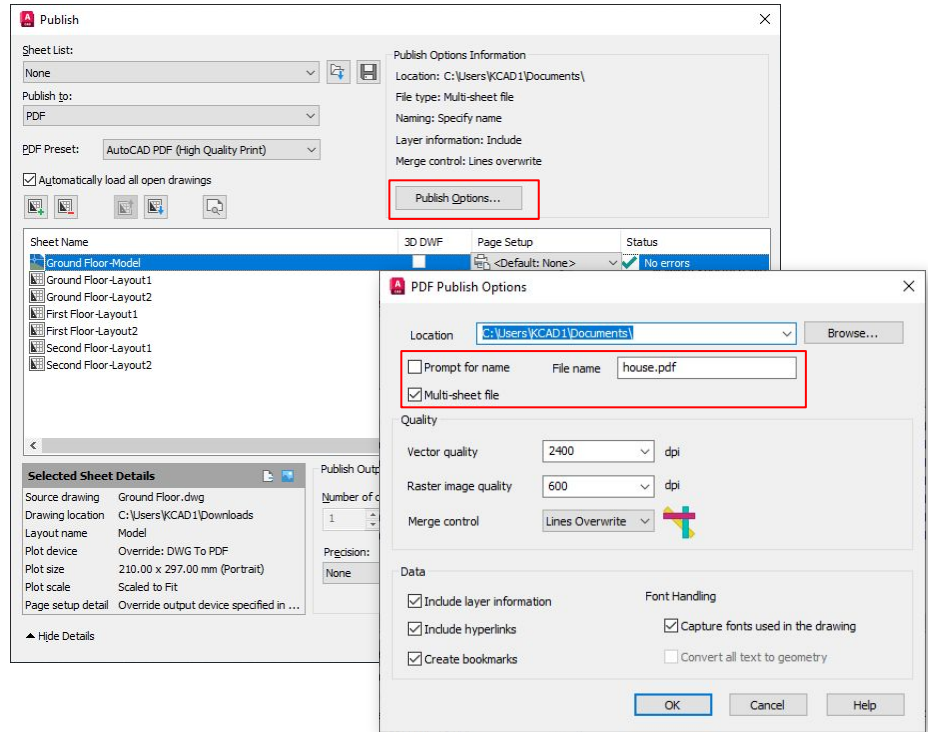

Module 3 Publish Setting

Plot Stamp

The **Include Plot Stamp** option in AutoCAD adds a stamp with metadata (like date, sheet number, and drawing name).

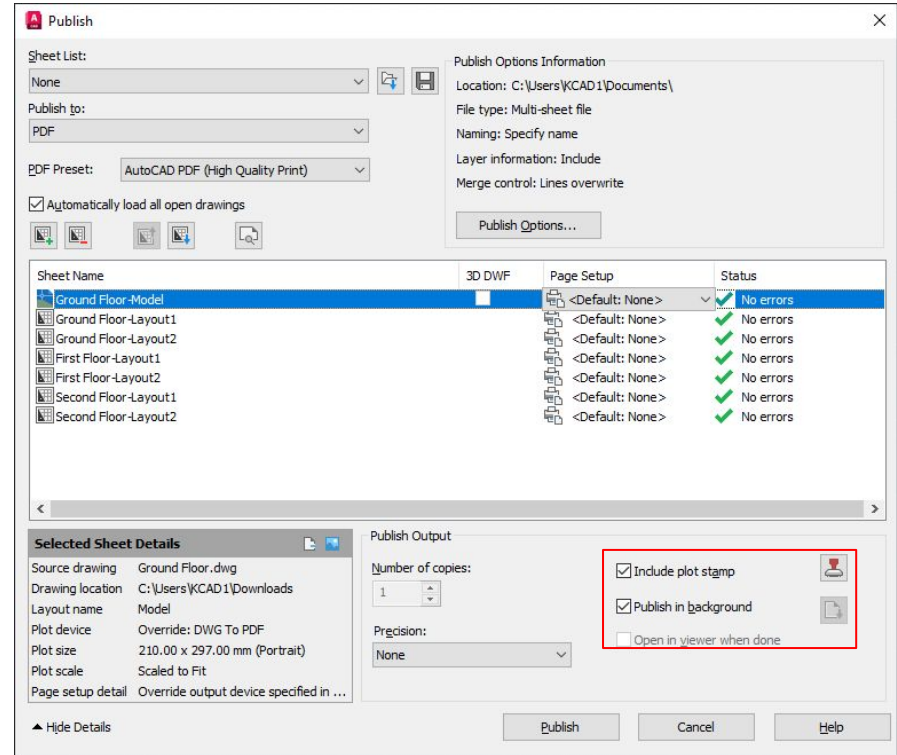
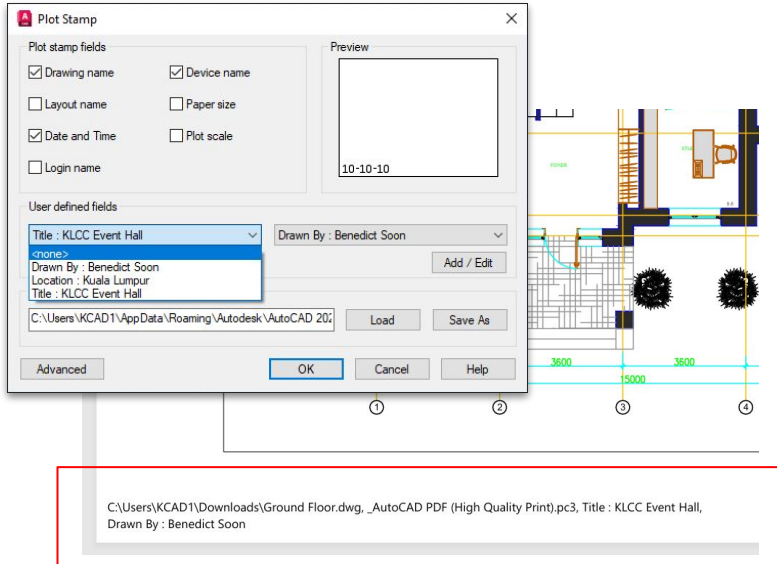

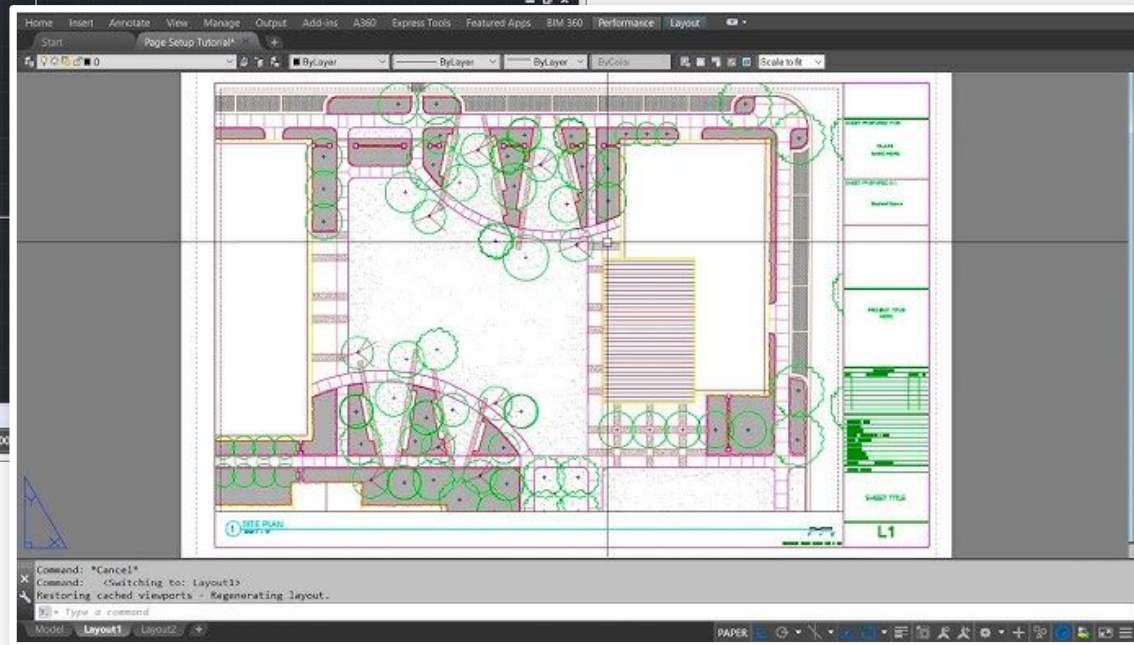
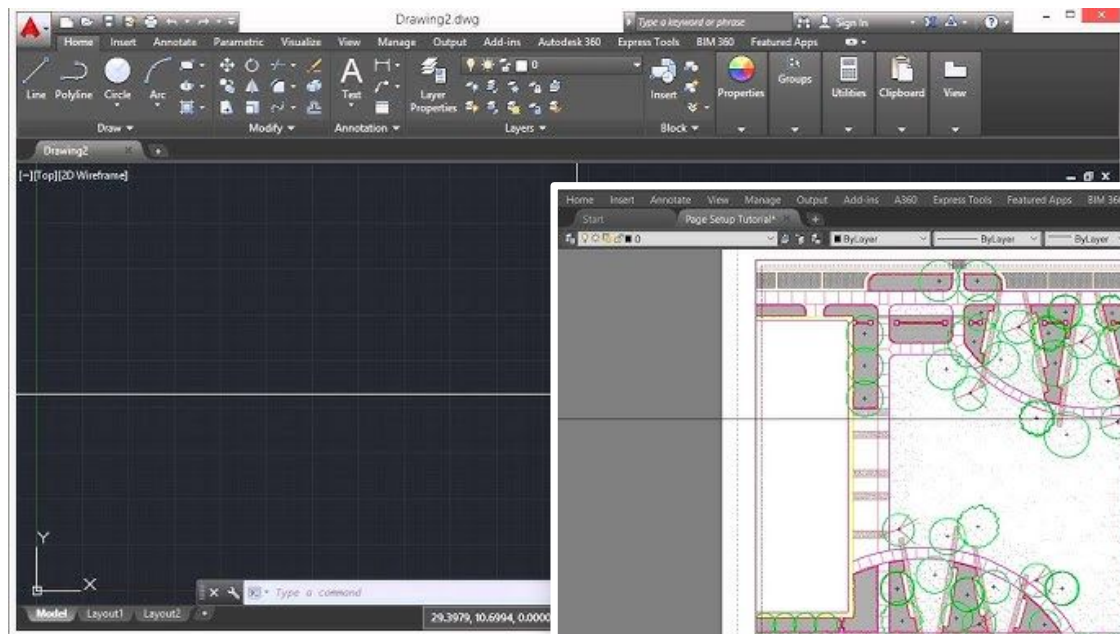

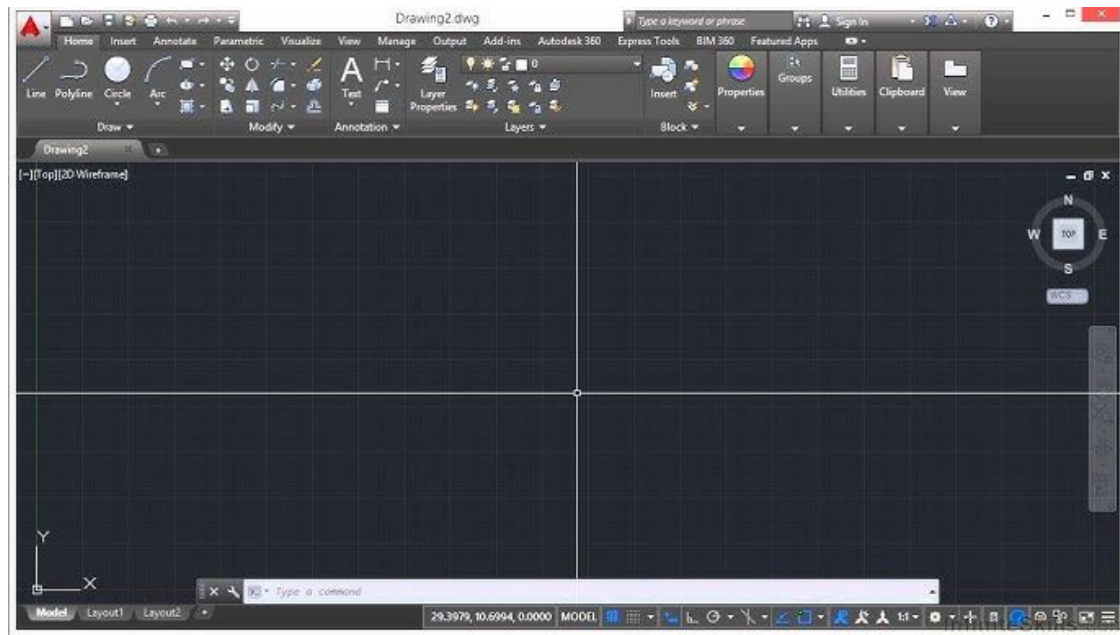

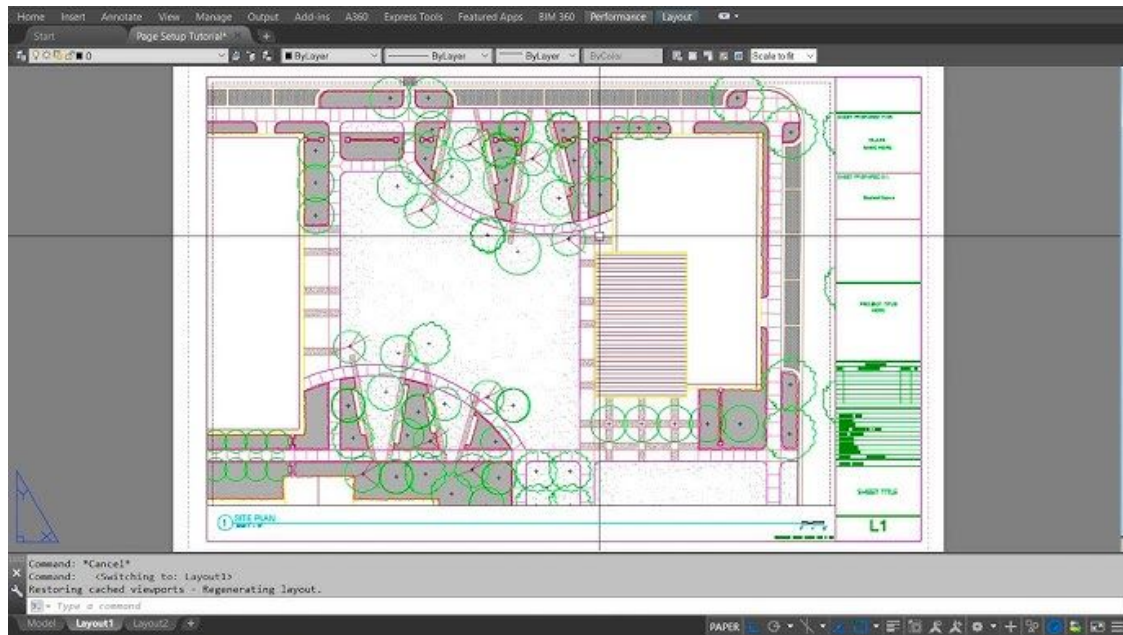

Important Points

1. Drawing Limit **LIM**
2. Layer Setup **LA**
3. Object Property **PRO**
4. Block **B**
5. Layout Configuration **PAGE**
6. Public to PDF **PUB**



Module 4



Module 3 Super Hatch

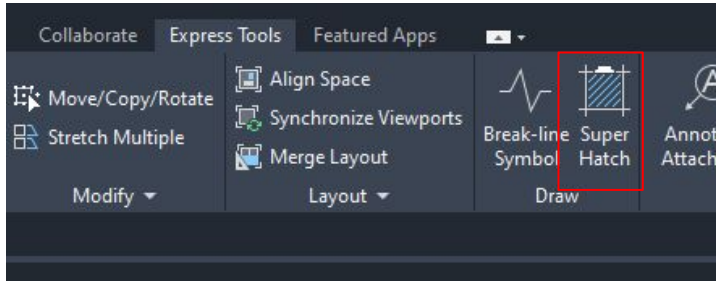

Super Hatch **SUPER**

In AutoCAD, hatch is patterns or colors to distinguish materials or sections in a drawing. It can be applied to closed shapes and customized in terms of scale, angle, and transparency.

Our Lesson - Module 4

- 1. Navigating Model Space Viewport Controls**
To mastering viewport controls in the Model Space. These controls empower you to precisely view and manipulate your 2D and 3D drawings.
- 2. Crafting 3D Excellence: Model Visual Styles**
Blocks allow you to efficiently reuse and manage design components and maintaining consistency throughout your projects.
- 4. Unleashing 3D Creativity: Exploring Extrude, Subtract, Union, and Presspull**
Learn to extrude, subtract, union, and press-pull shapes, enabling you to sculpt and manipulate your 3D objects.
- 5. From 2D to 3D: The Art of Converting Drawings**
Convert 2D drawings into immersive 3D models in AutoCAD. This process bridges the gap between flat designs and immersive spatial representations, opening up boundless possibilities for design exploration.

Module 4

Part 1



Module 4 Before 3D

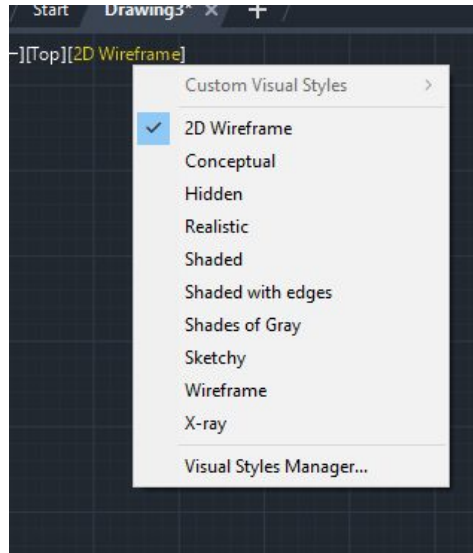
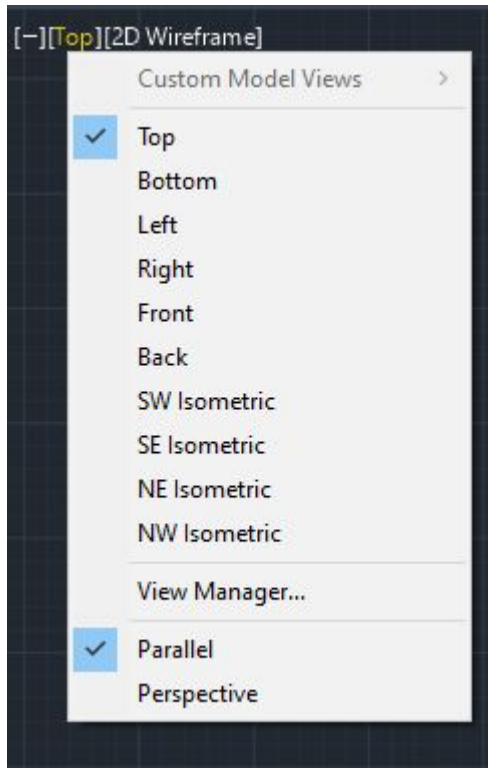

Module 4 Basic 3D

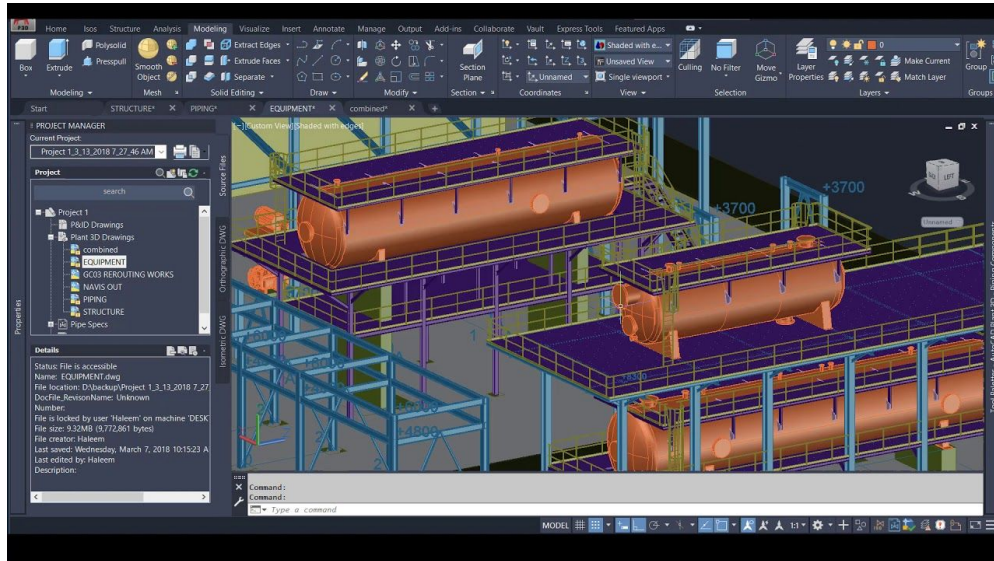

AutoCAD 3D is an advanced feature of AutoCAD that allows users to create, edit, and visualize three-dimensional models and objects. It provides a comprehensive set of tools for modeling, including the ability to create basic shapes like boxes, spheres, and cylinders, as well as more complex forms through operations like extrusion, lofting, and sweeping.

AutoCAD 3D includes features for rendering, which allows users to apply materials, textures, and lighting effects to create realistic visualizations of their designs. Additionally, users can navigate in a 3D space using various view options, making it easier to inspect the model from different angles and perspectives.

Overall, AutoCAD 3D enhances the design process by providing powerful tools for creating and visualizing complex three-dimensional structures, facilitating better communication of ideas and improving accuracy in design.

Module 4 Extrude, Subtract, Union, Intersection

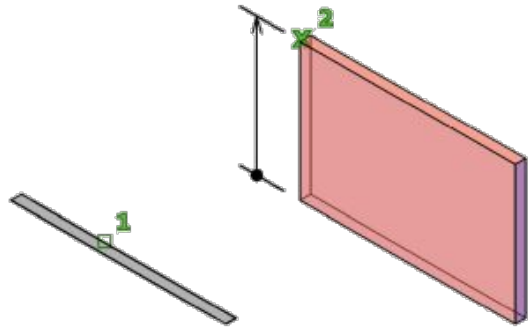

Extrude

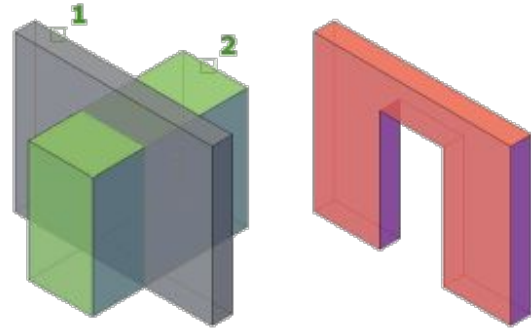

Subtract

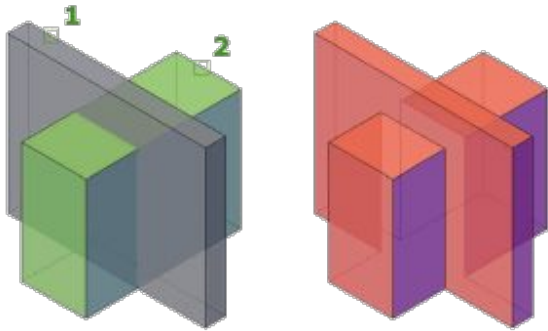

Union

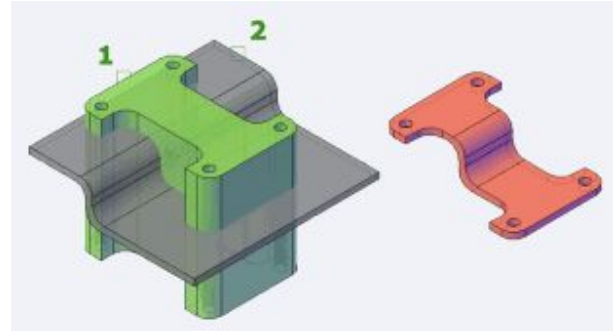

Intersection

Module 4 Part 1

Exercises



Module 4 Exercise 2.1

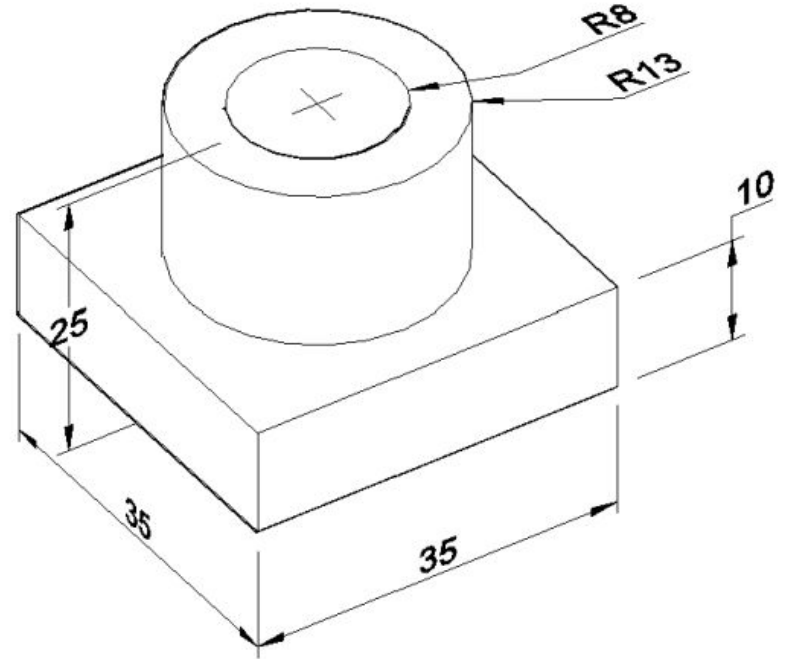
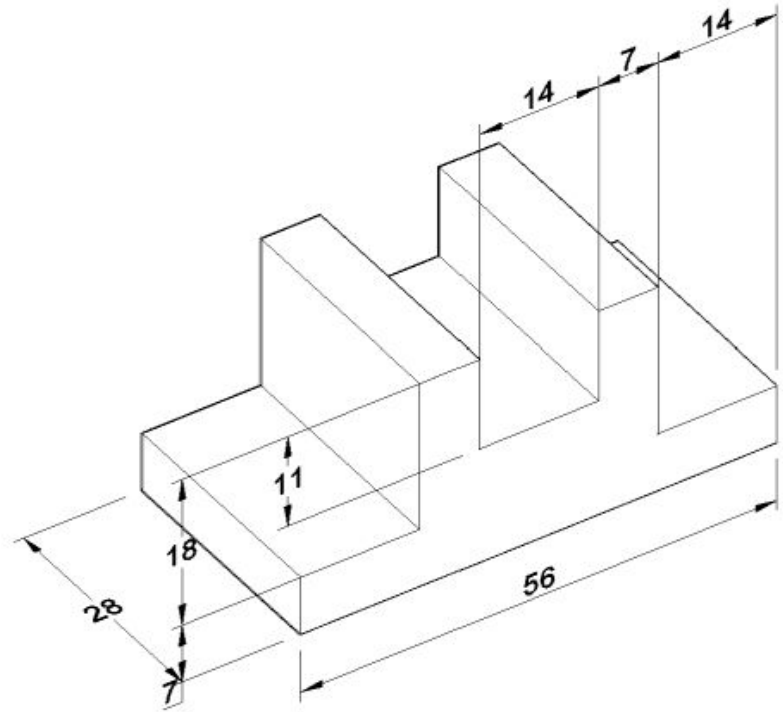

Module 4 Exercise 2.2

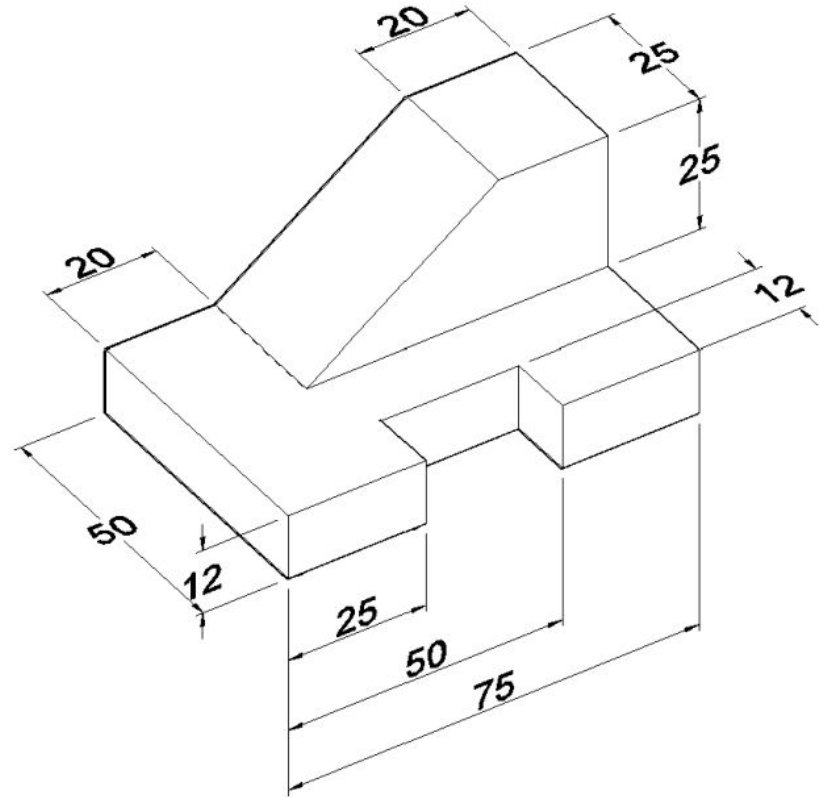
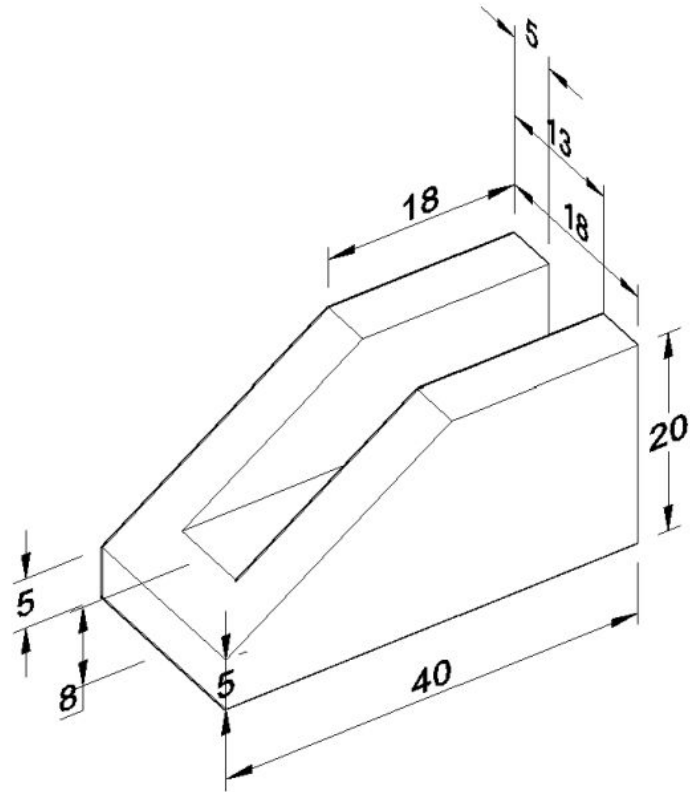

Module 4 Exercise 2.3

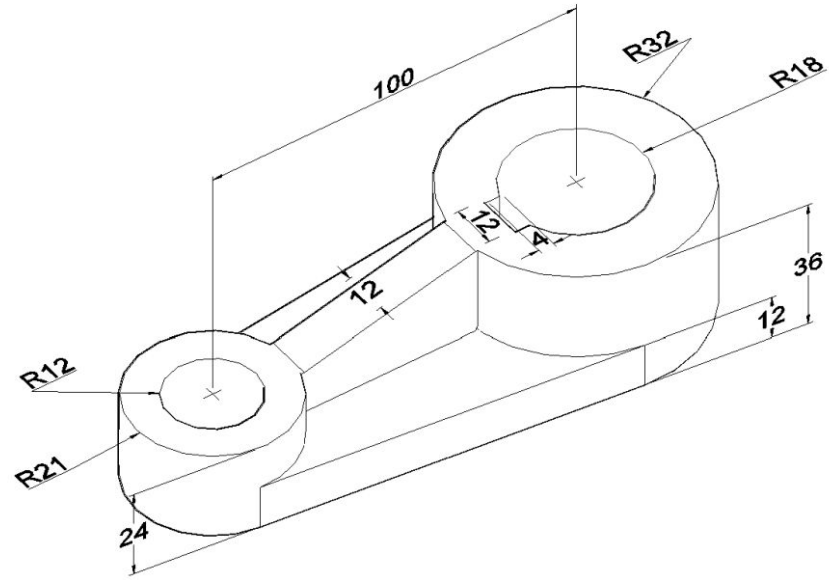
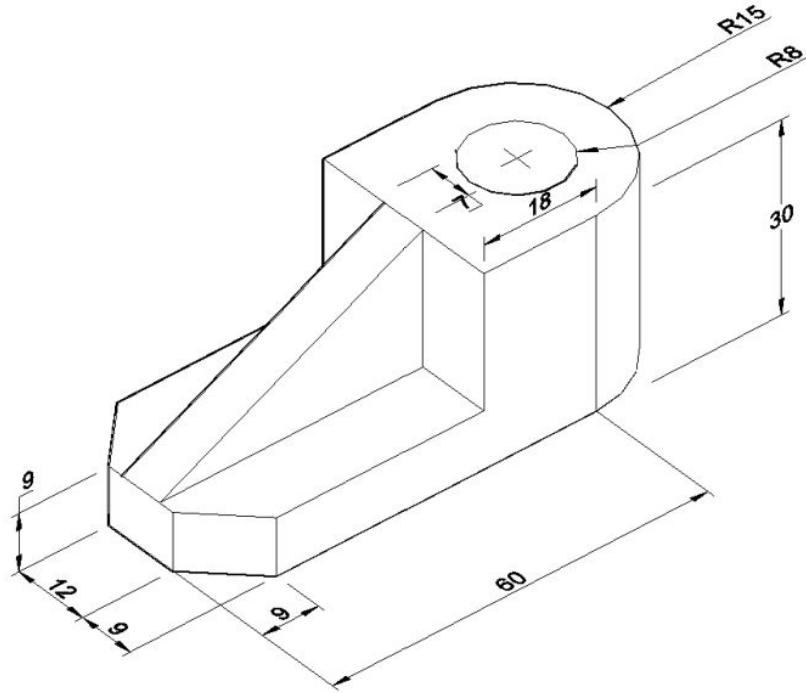

Important Points

- | | |
|--------------|--------------|
| 1. Extrude | EXT |
| 2. Subtract | SUB |
| 3. Union | UNI |
| 4. Presspull | PRESS |



AutoCAD

Task 3



TASK 3

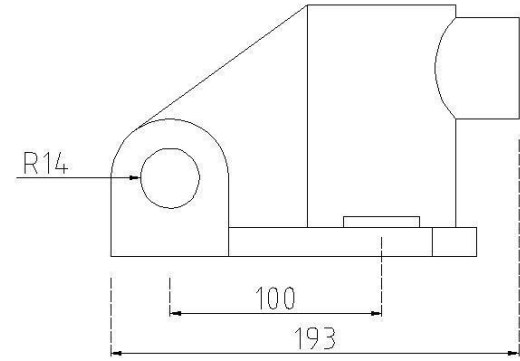
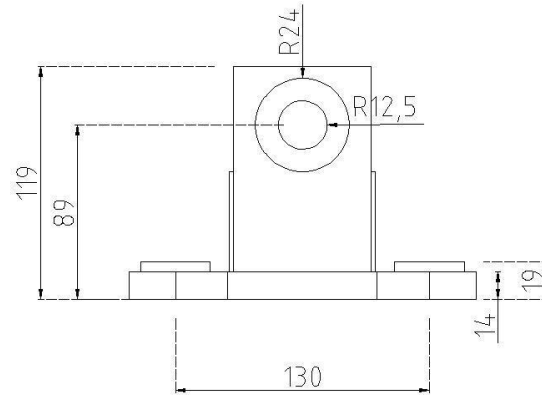
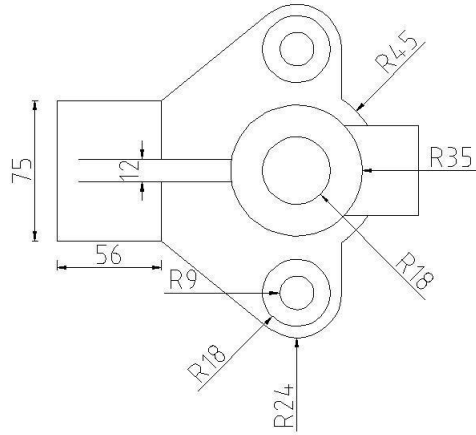

Download
Task 5.DWG

Presspull, Sweep, Loft, Revolve

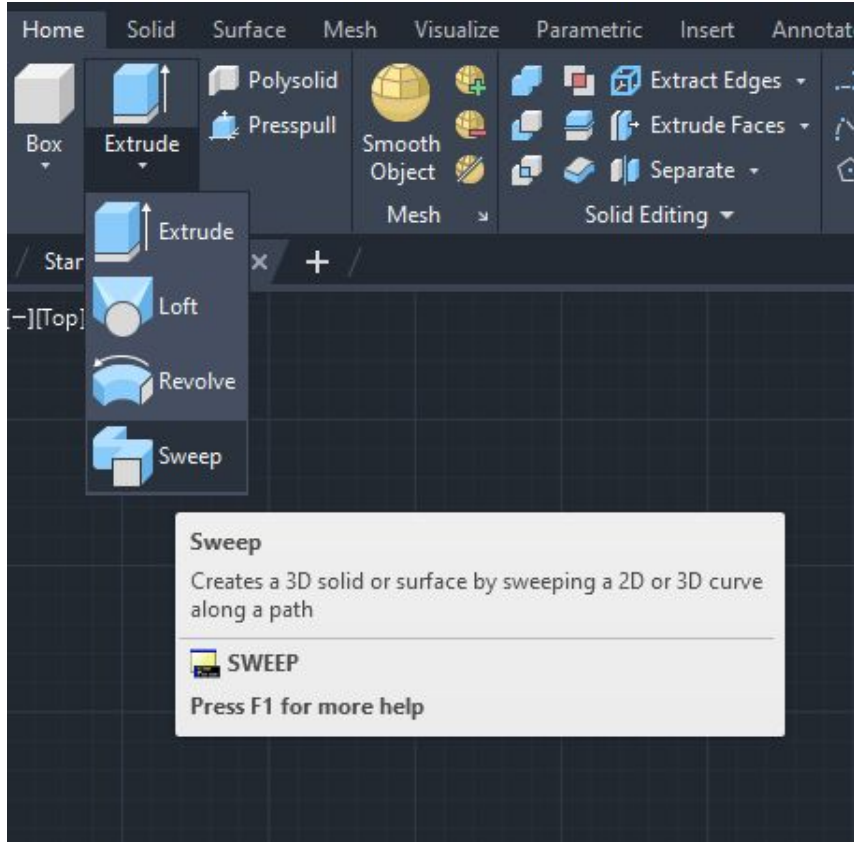

Important Points

1. 3D Modeling
2. Extrude, Subtract, Union, Intersec
3. Presspull
4. Loft
5. Sweep
6. Revolve

TASK 5

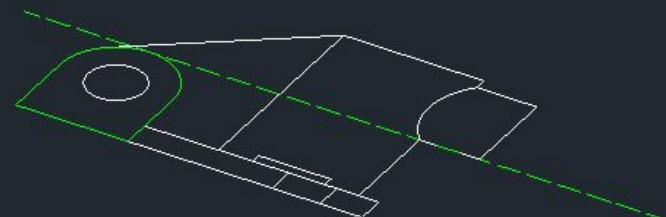
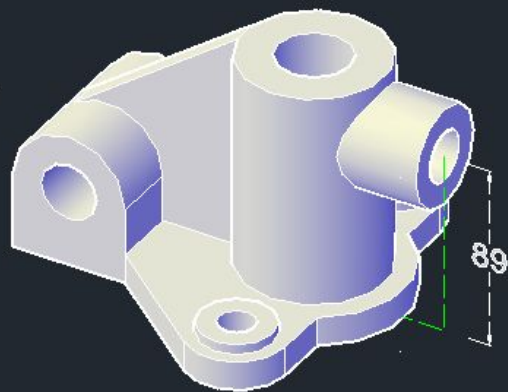
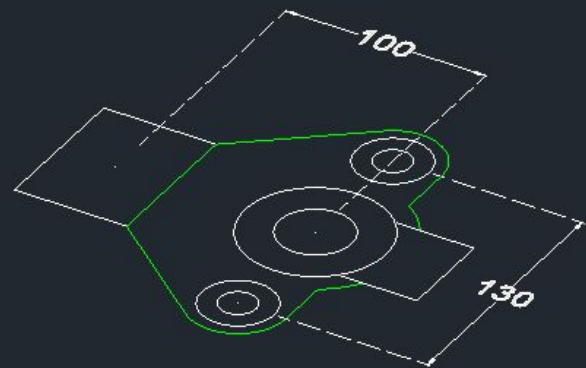

Module 4

Part 2



What is Loft **LOF**

In AutoCAD, the "Loft" command is used for 3D modeling by blending between two or more 2D shapes to create a smooth and continuous 3D surface or solid. This tool is valuable for generating complex shapes and can be accessed through the "3D Modeling" workspace or by typing "LOFT" in the command line.

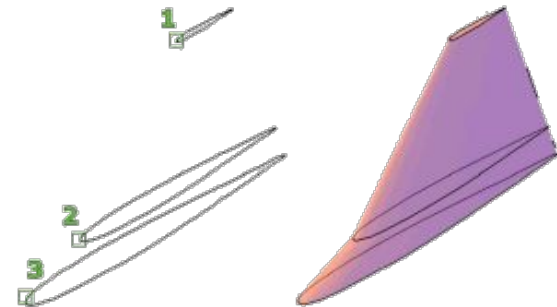
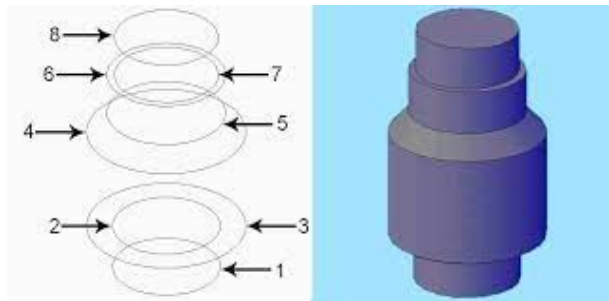
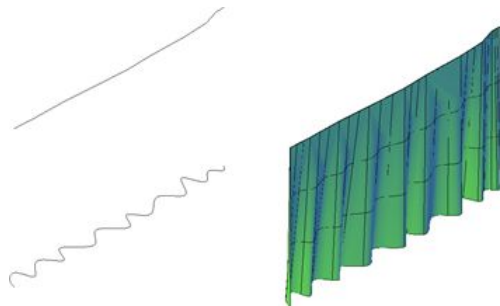

Important Points

1. **Surface Modeling Mode**
- 2.

Module 4 Part 2

Exercises



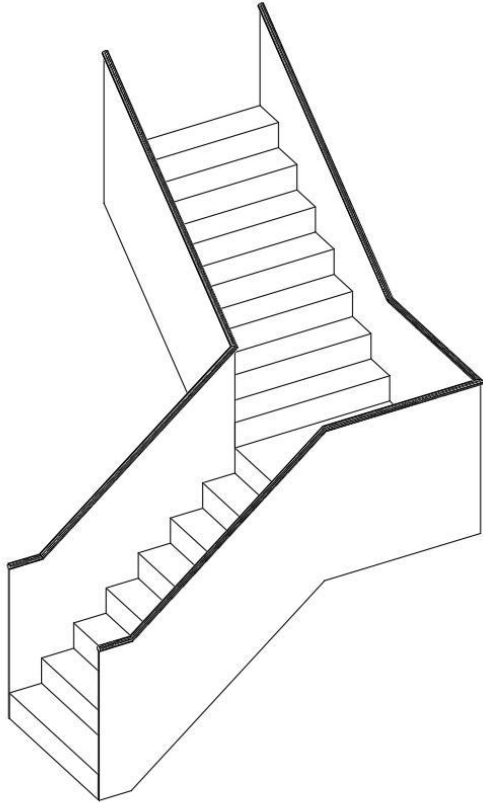

step: L120, W25, H20

handrail: H120, W1, R2

What will you learn?

1. Extrude & Presspull
2. 3D Polyline
3. 3D Fillet
4. Line Loft Command

Module 4 Exercise 4

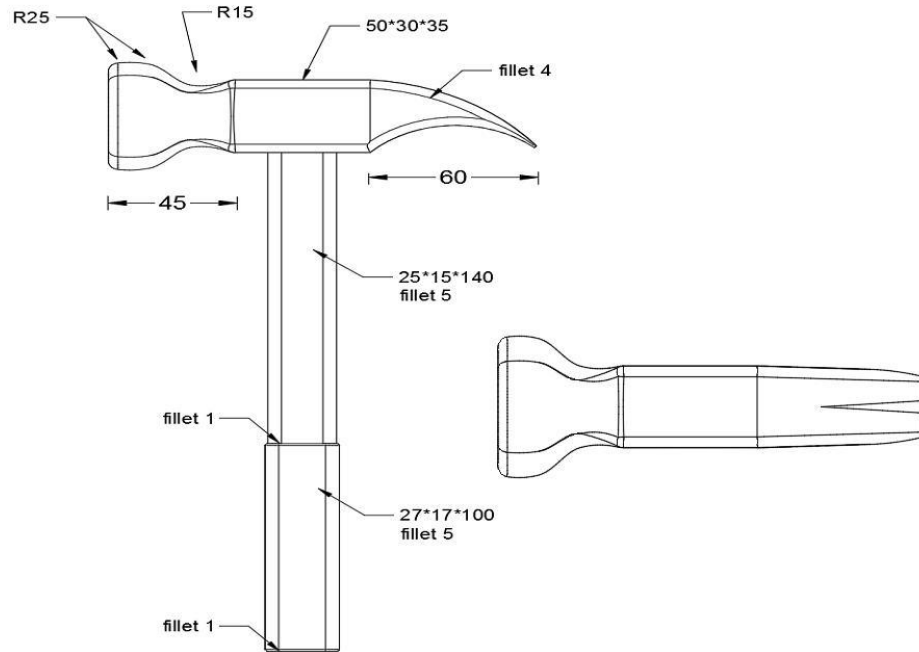

What will you learn?

1. Extrude & Presspull
2. Shape Loft Command
3. 3D Fillet

Module 4 Exercise 4

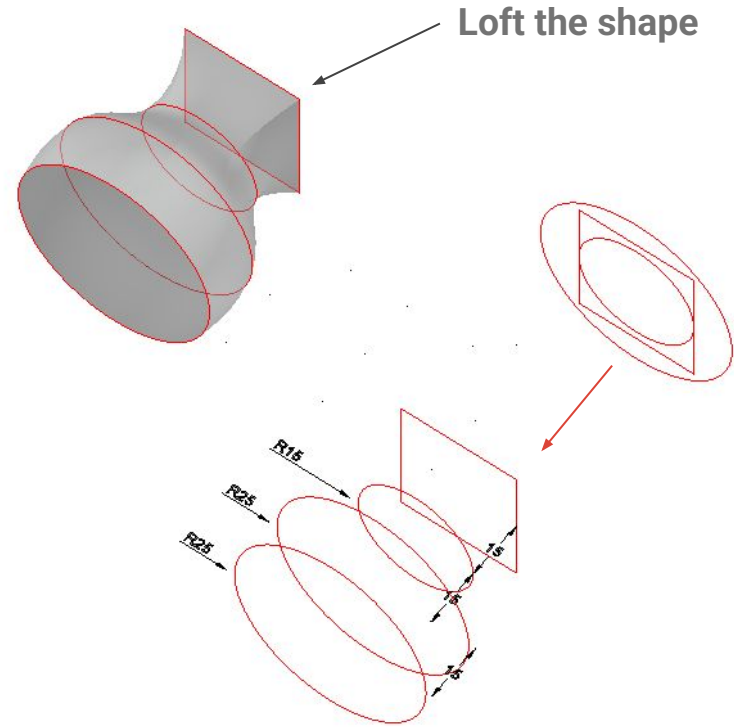
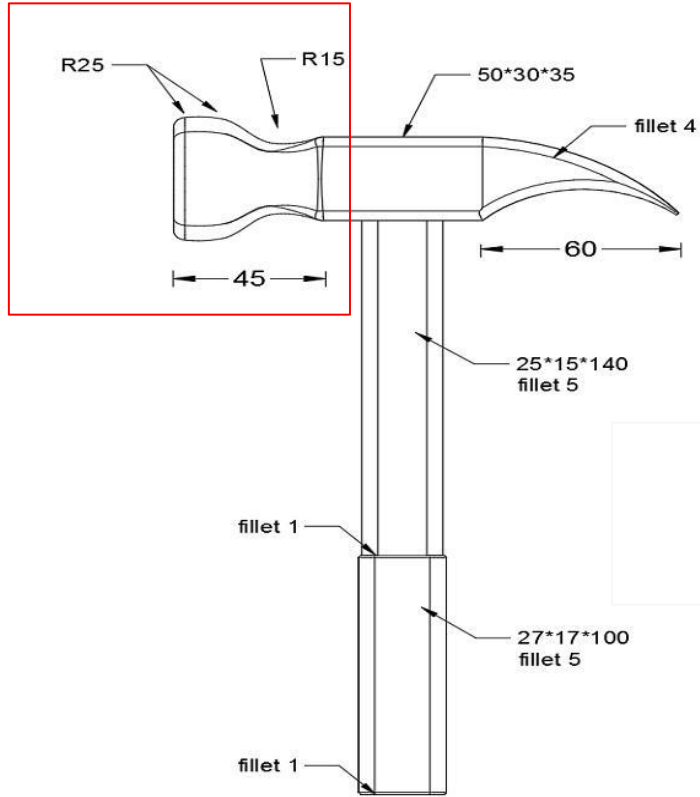

Module 4 Exercise 4

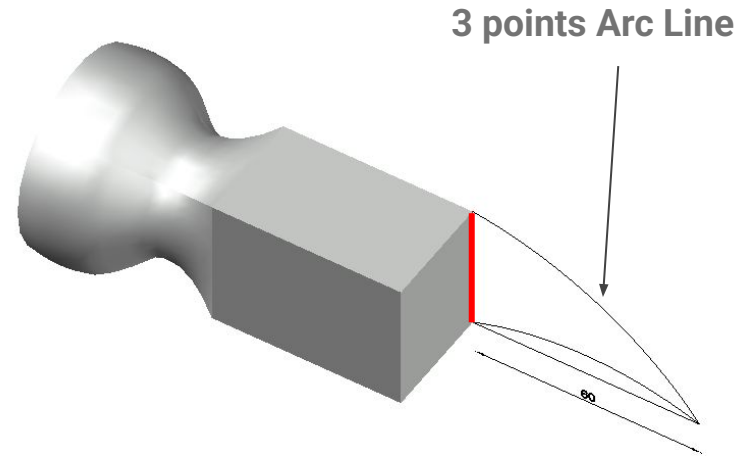
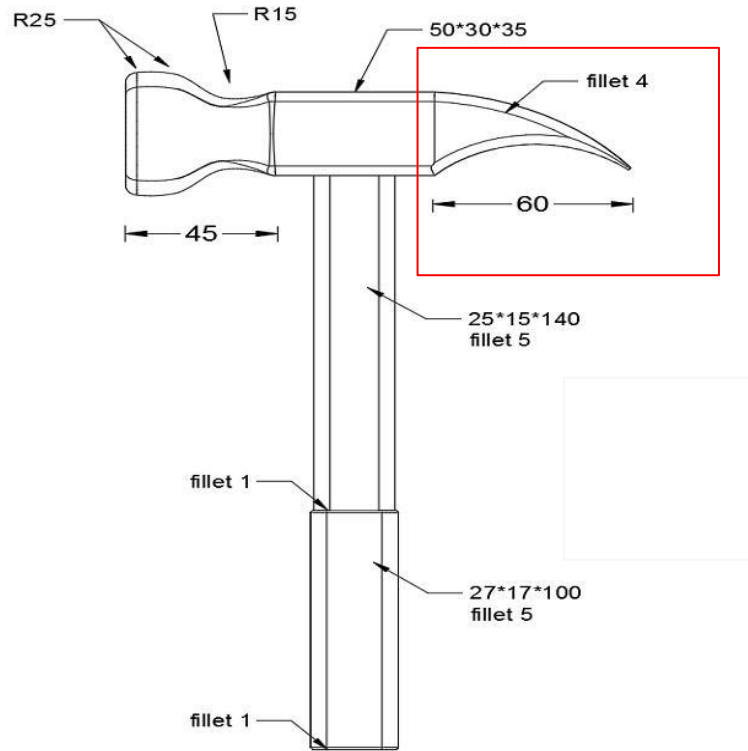

Module 4 Exercise 4

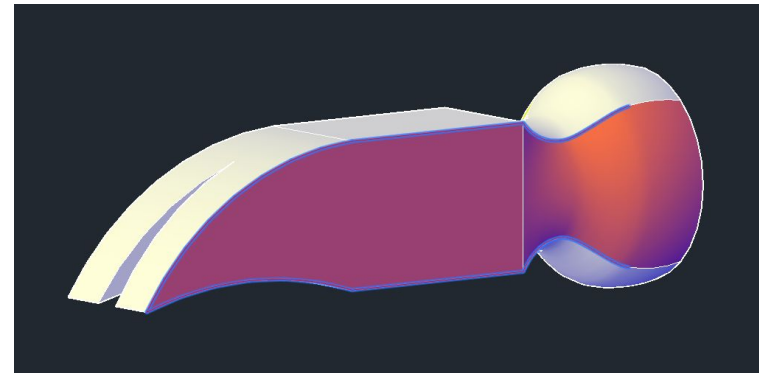
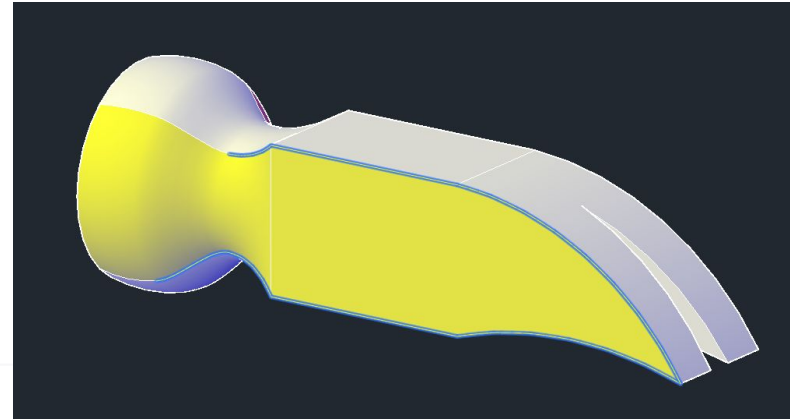
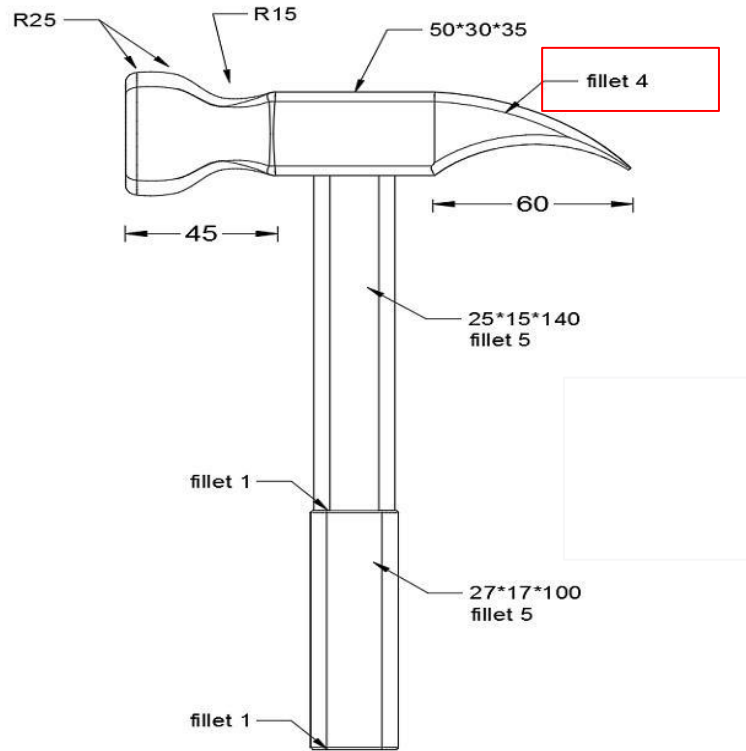

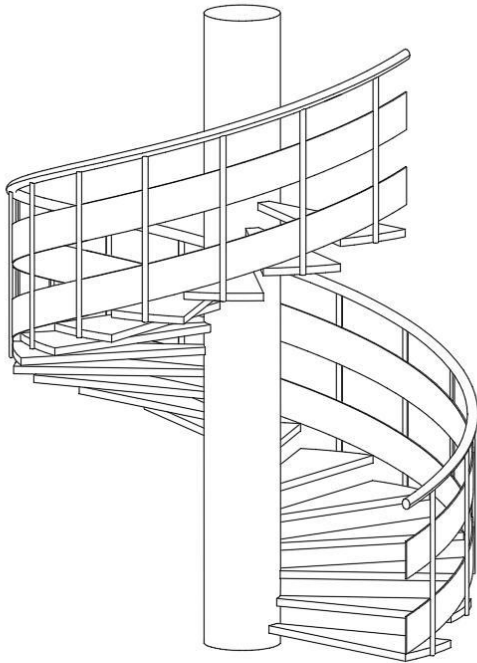

staircase width: R150, column: R25 H420

step: 18, H5, total height 300

stair pillar: R2, H115

handrail: 1*25, gap 25, R3.5

What will you learn?

1. Helix
2. Path Array
3. Sweep

What is Helix?

A helix is a three-dimensional curve characterized by a consistent circular motion around a central axis, forming a spiral shape.

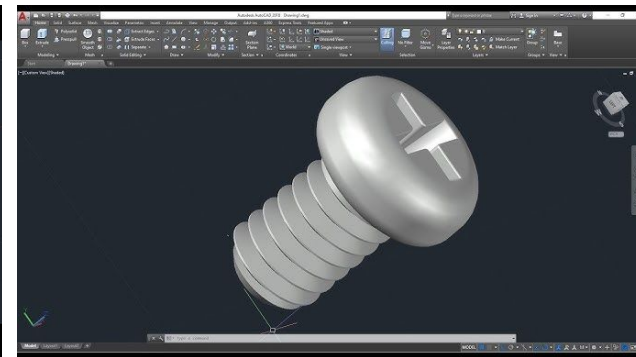
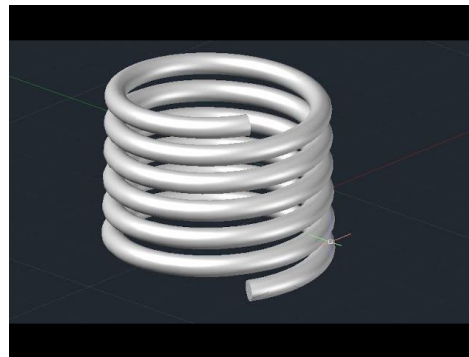
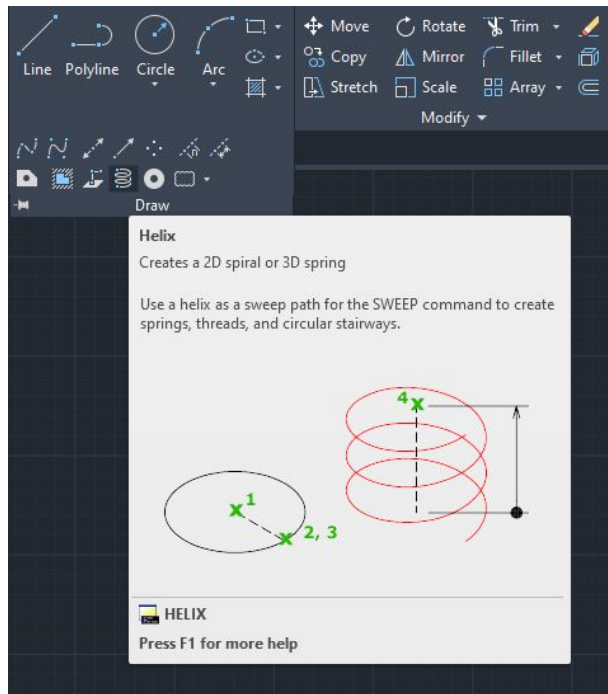

What is Path Array?

The path array feature allows duplicate the selected objects along a specified path, facilitating the creation of linear arrangements following a designated trajectory

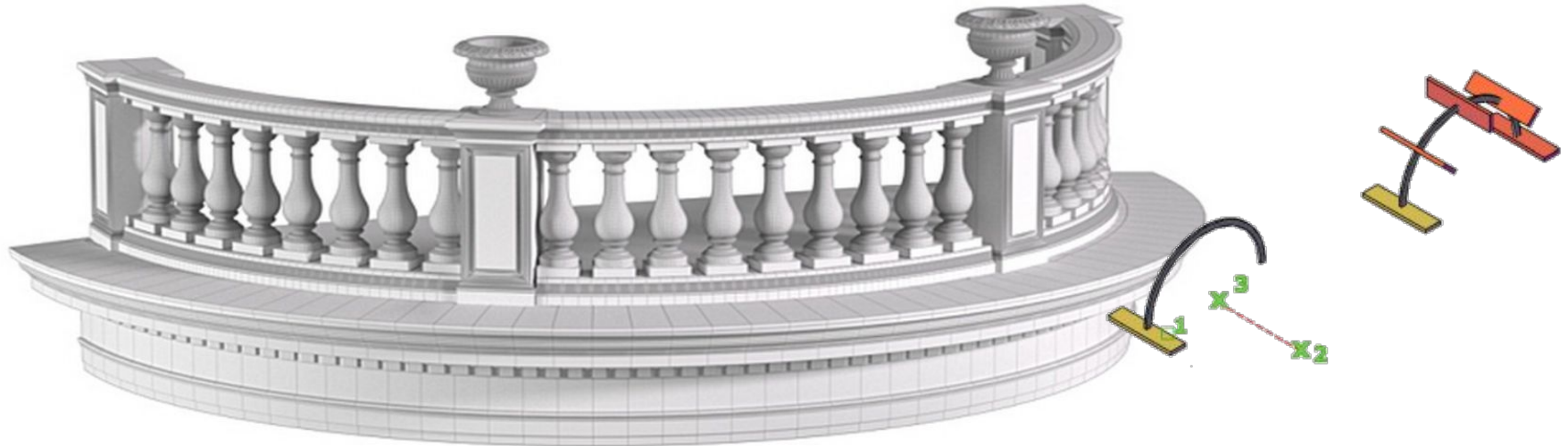

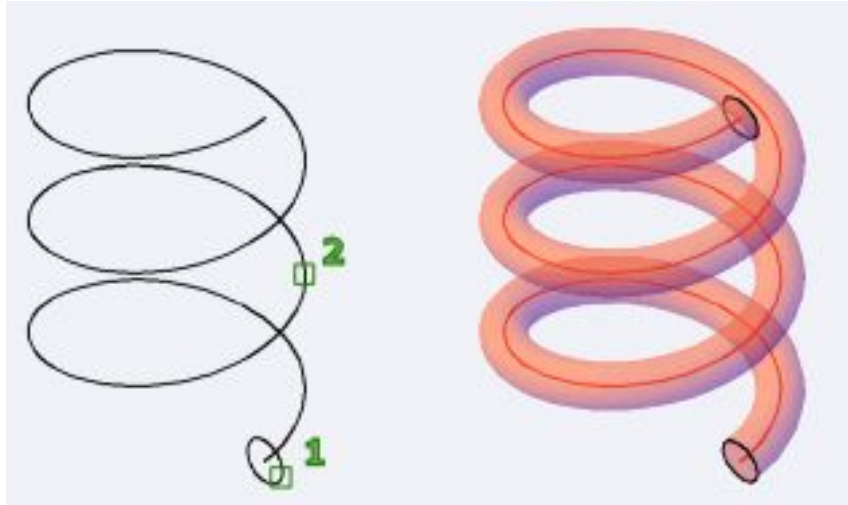

What is Sweep?

AutoCAD's "SWEEP" command enables the swift creation of 3D solids or surfaces by extruding a chosen 2D profile along a specified path

Module 5 Assignment

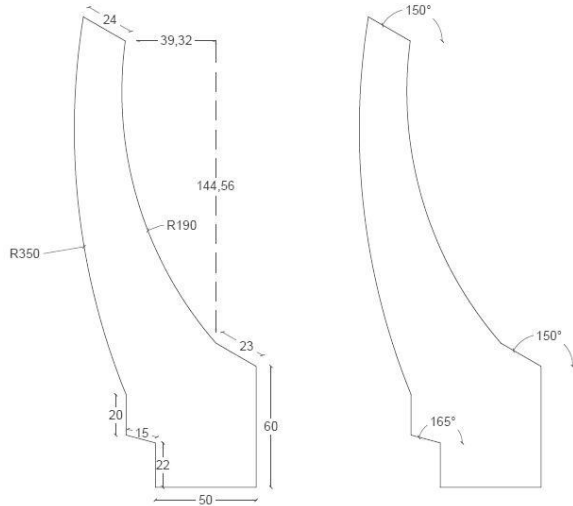
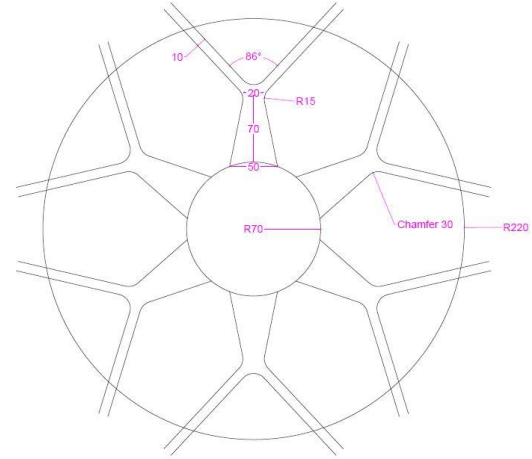
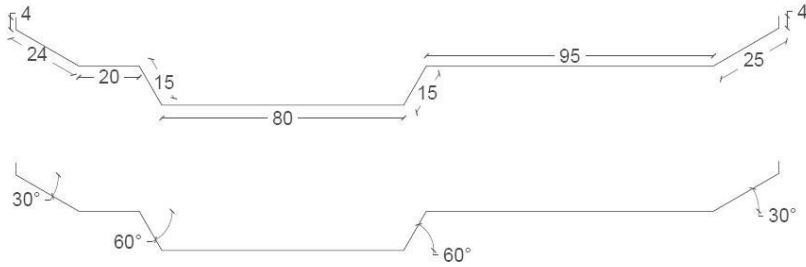

Revolve REV

The **REVOLVE** command in AutoCAD is used to create 3D solid or surface objects by revolving a 2D object around an axis. It's great for creating objects with rotational symmetry, like cylinders, cones, and other round shapes.

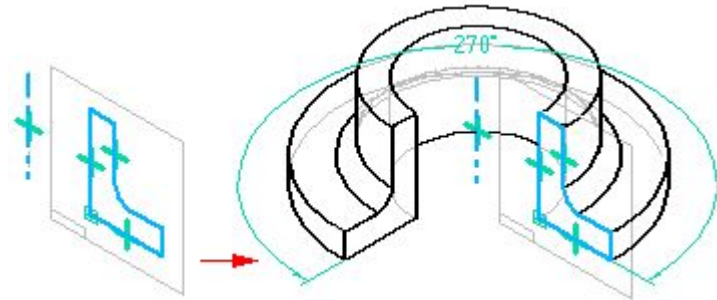

Revolve

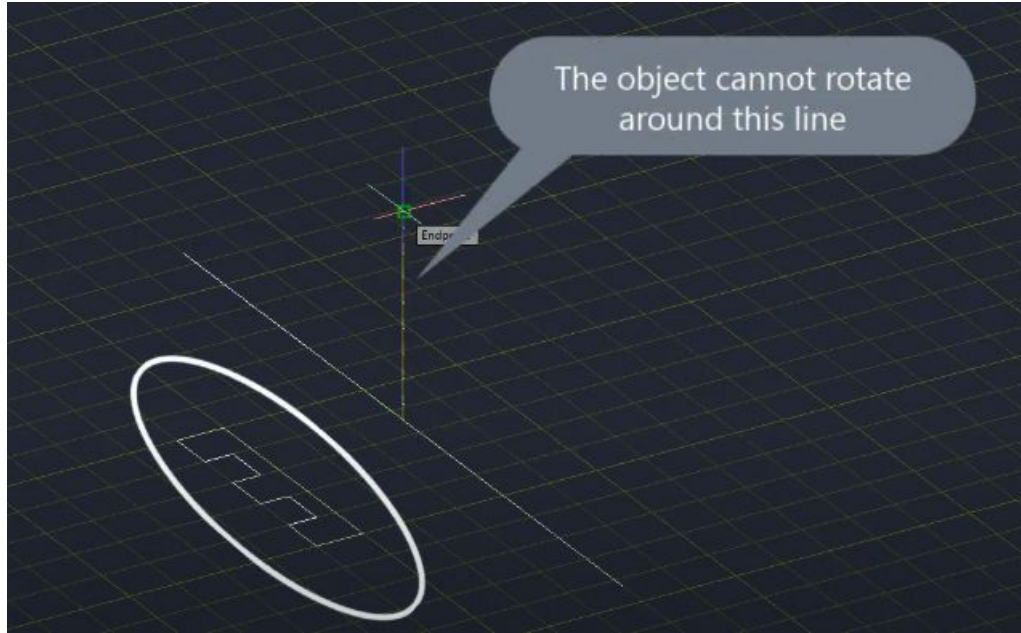

The axis and the 2D profile must both be in the same plane (i.e., the same flat surface). This ensures the object revolves correctly around the axis to form a symmetrical 3D shape.

Module 5

Part 1



Module 5

Part 1



Benedict Soon

Facebook

Module 5

1. **Title Block**

In AutoCAD, a title block is a standardized information area on a drawing, including details like project name and date. Attributes are variable text elements within a block, like placeholders in a title block, allowing for specific information to be entered for each drawing instance.

2. **3D Material Library**

AutoCAD's material settings enable users to add realistic textures to 3D models, with options for customization in color and texture, vital for creating accurate and visually appealing renderings.

3. **Rendering Setup**

AutoCAD's rendering setup involves adjusting lighting, camera angles, and materials to create realistic images from 3D models, essential for visualizing and communicating design projects effectively.

Module 5 - 2D Floor plan

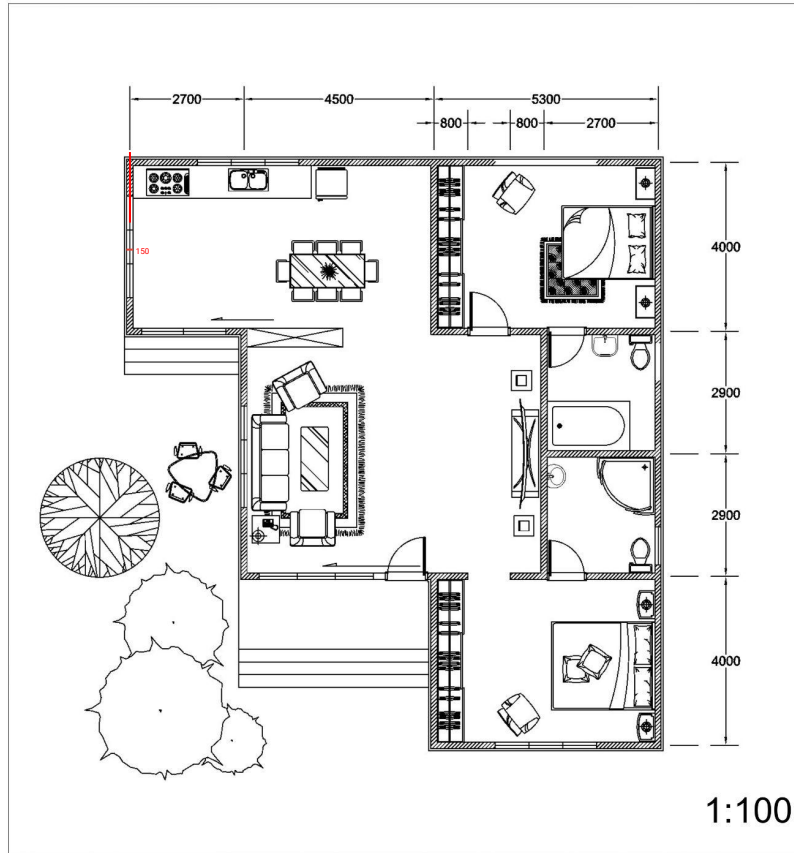

Specification		
Wall	W150, H3000	
1 P Door	L1000, H2000	
3 P Sliding Door	L2700, H2000	
2 P Sliding Door	L2000, H2000	
Room Window	L2400, H1200	
Bathroom Window	L900, H600	
Floor	H600, Offset 50	
Roof	Offset 750, Taper Angle 60°	
Note		
Date	Drawn By	Checked By
Cop & Sign		

Module 5 - 2D Floor plan

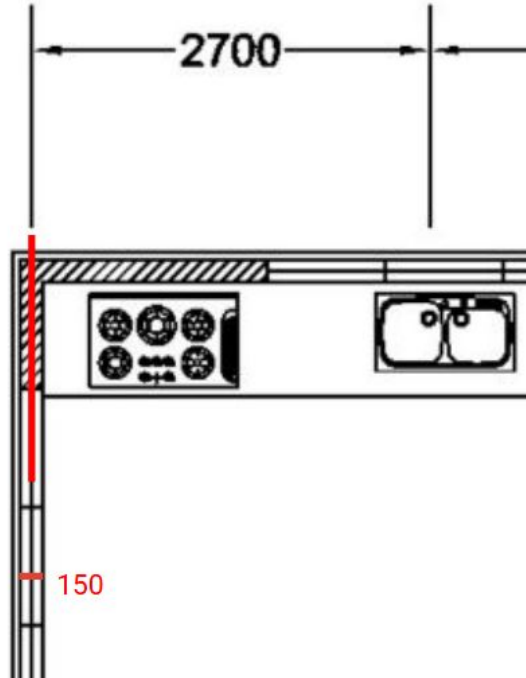

Module 5 - Import External Block

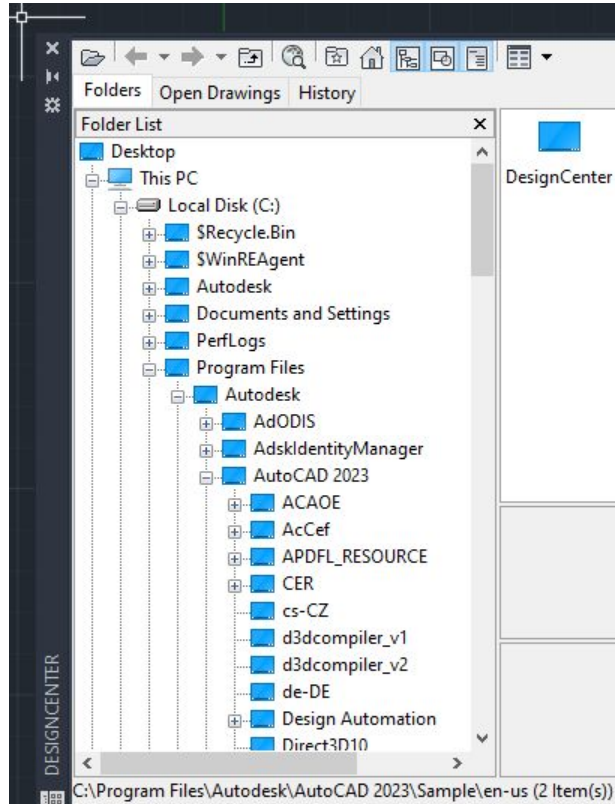

In AutoCAD, an external block is a reusable drawing element stored in a separate file (typically a `.dwg` or `.dxf`). To import it, use the AutoCAD Design Center **ADC** command, browse for the block file in the Directory. External blocks enhance efficiency and consistency by allowing you to reuse design elements across multiple projects while keeping file sizes manageable. Additionally, updates to the original block can be easily reflected in your drawing.

Module 5 - 3D Wall Polysolid

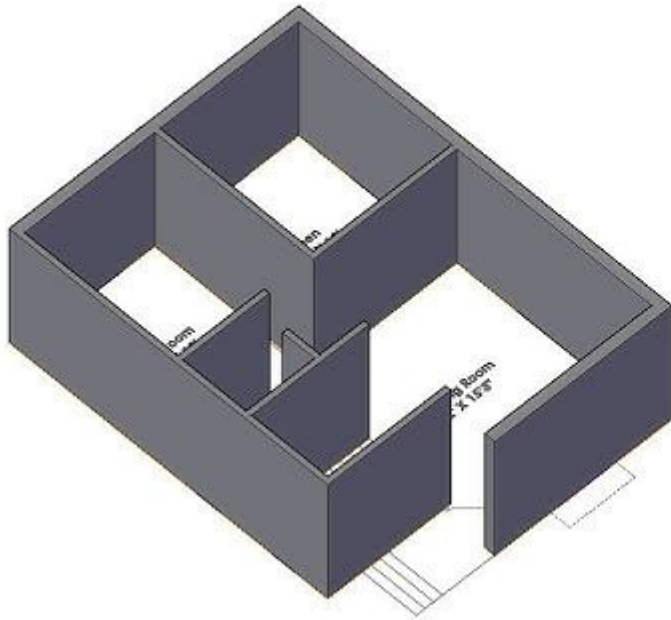

A polysolid **POLYS** in AutoCAD is a 3D solid object that consists of a series of connected linear segments. It's often used to create walls, beams, or other structures with varying heights or widths. You can define a polysolid by specifying the base points, height, and width, allowing for the creation of complex shapes with ease.

Module 5 - 3D Wall Polysolid

A polysolid **POLYS** in AutoCAD is a 3D solid object that consists of a series of connected linear segments. It's often used to create walls, beams, or other structures with varying heights or widths. You can define a polysolid by specifying the base points, height, and width, allowing for the creation of complex shapes with ease.

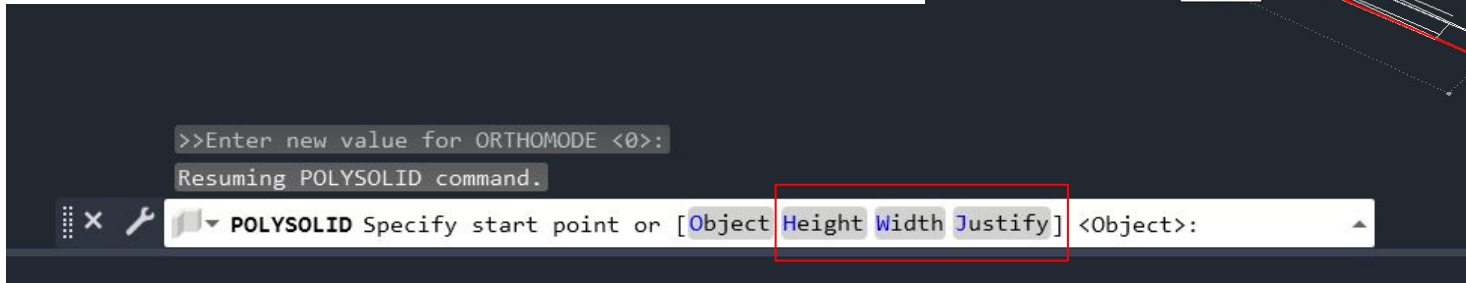
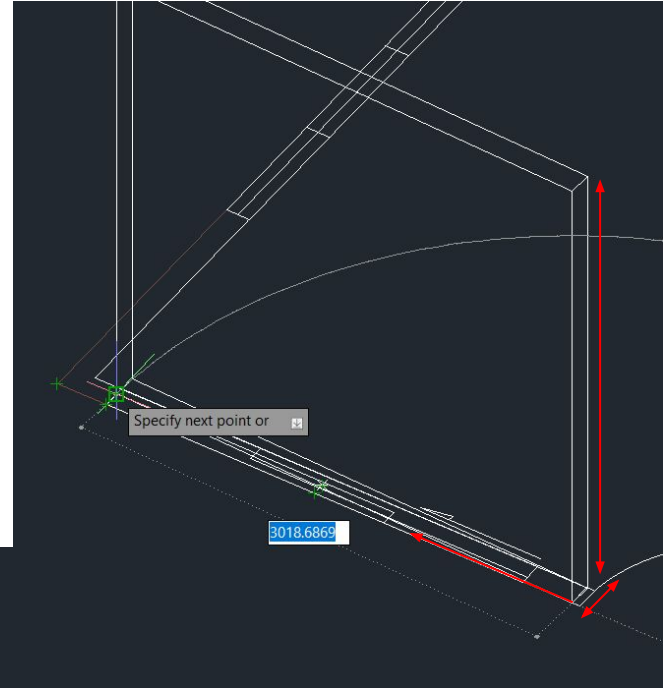

Module 5 - 3D Wall Polysolid

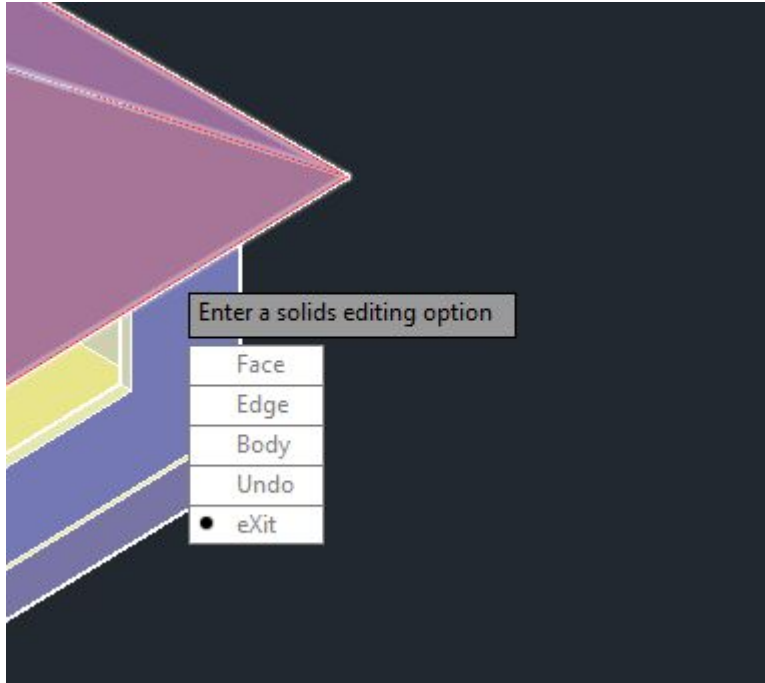

SOLID EDIT SOLIDE is a command in AutoCAD specifically designed for editing 3D solid objects. It provides a set of tools that allow you to manipulate solid geometry efficiently. Key functionalities include:

- **Faces:** Edit individual faces of a solid.
- **Edges:** Modify edges, including rounding or filleting.
- **Shell:** Create a hollow version of a solid while keeping its outer shape.
- **Convert:** Change a solid into a surface or vice versa.

Module 5 - 3D Layout

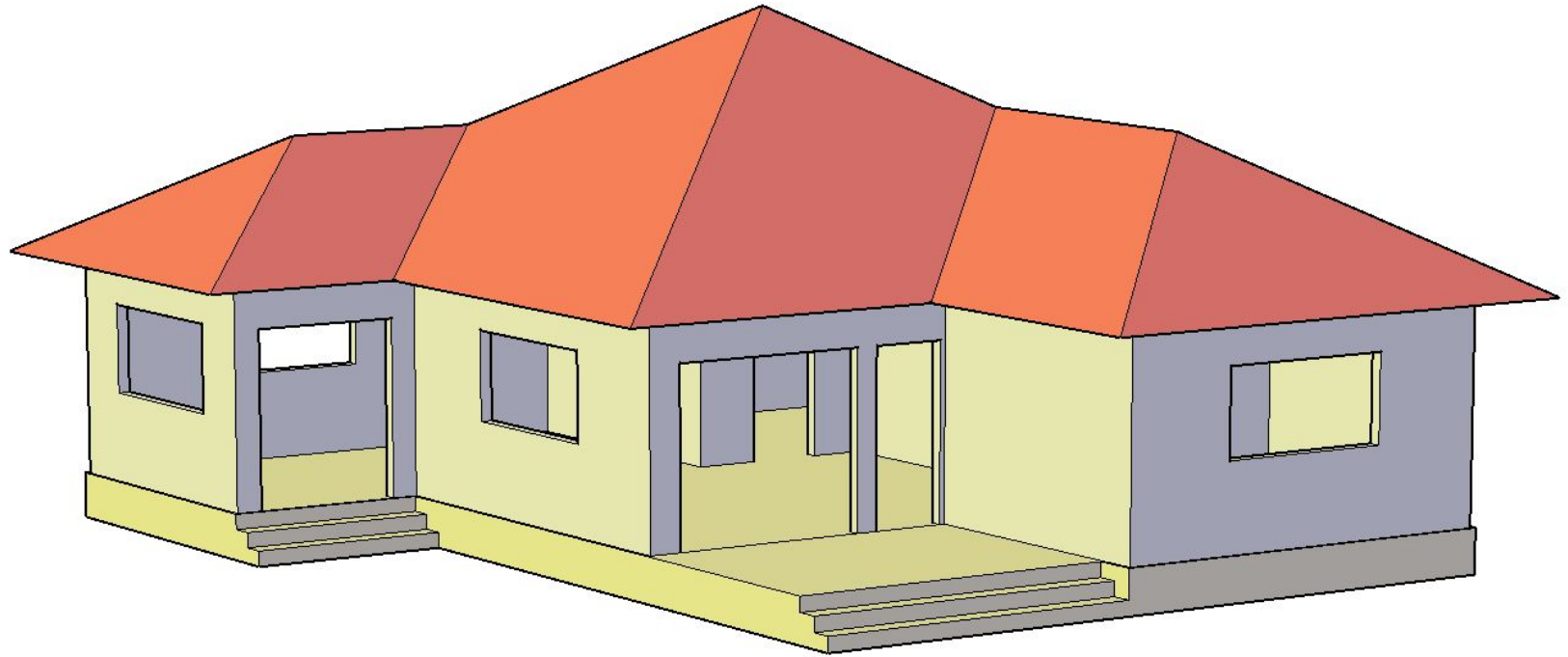

Module 5 - Import Title Block

1: 200

1: 200

1: 200

1: 160

NOTE	
TITLE	
SUBJECT	
CLIENT	
ADDRESS	
CAD REF	DATE
DRAWING NO.	SCALE
DRAWN	
CHECKED	

A **title block** is a standardized section on a drawing sheet that contains essential information such as the project title, drawing number, date, scale, author, company logo, and revision history.

Module 5 Attribute - Title Block

NO.	DATE	REVISION	BY
DWG TITLE			
ENGINEER	CHECKED BY		
JOB NO	DRAWN BY		
SCALE	DATE		
DWG NO			
SHEET NO			
<i>OF</i>			

The screenshot shows the 'Attribute Definition' dialog box with the following settings:

- Mode:** Invisible, Constant, Verify, Preset, Lock position, Multiple lines
- Insertion Point:** Specify on-screen, X: 0.0000, Y: 0.0000, Z: 0.0000
- Attribute:** Tag: [], Prompt: [], Default: []
- Text Settings:** Justification: Left, Text style: Standard, Text height: 1.0000, Rotation: 0, Boundary width: 0.0000
- Annotative
- Align below previous attribute definition

Buttons: OK, Cancel, Help

Attributes in AutoCAD are specific pieces of data that can be associated with a block definition. They act like variable text that can change for each instance of a block. For example, in a title block, attributes might include placeholders for the project name, number, or date. When you insert the block into a drawing, you can fill in these attributes with the relevant information. This makes attributes particularly useful for creating and managing drawing sheets where certain types of information are consistently required.

Module 5

Part 2

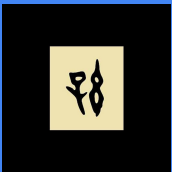

Benedict Soon
Facebook

Module 5 - 2D Floor plan

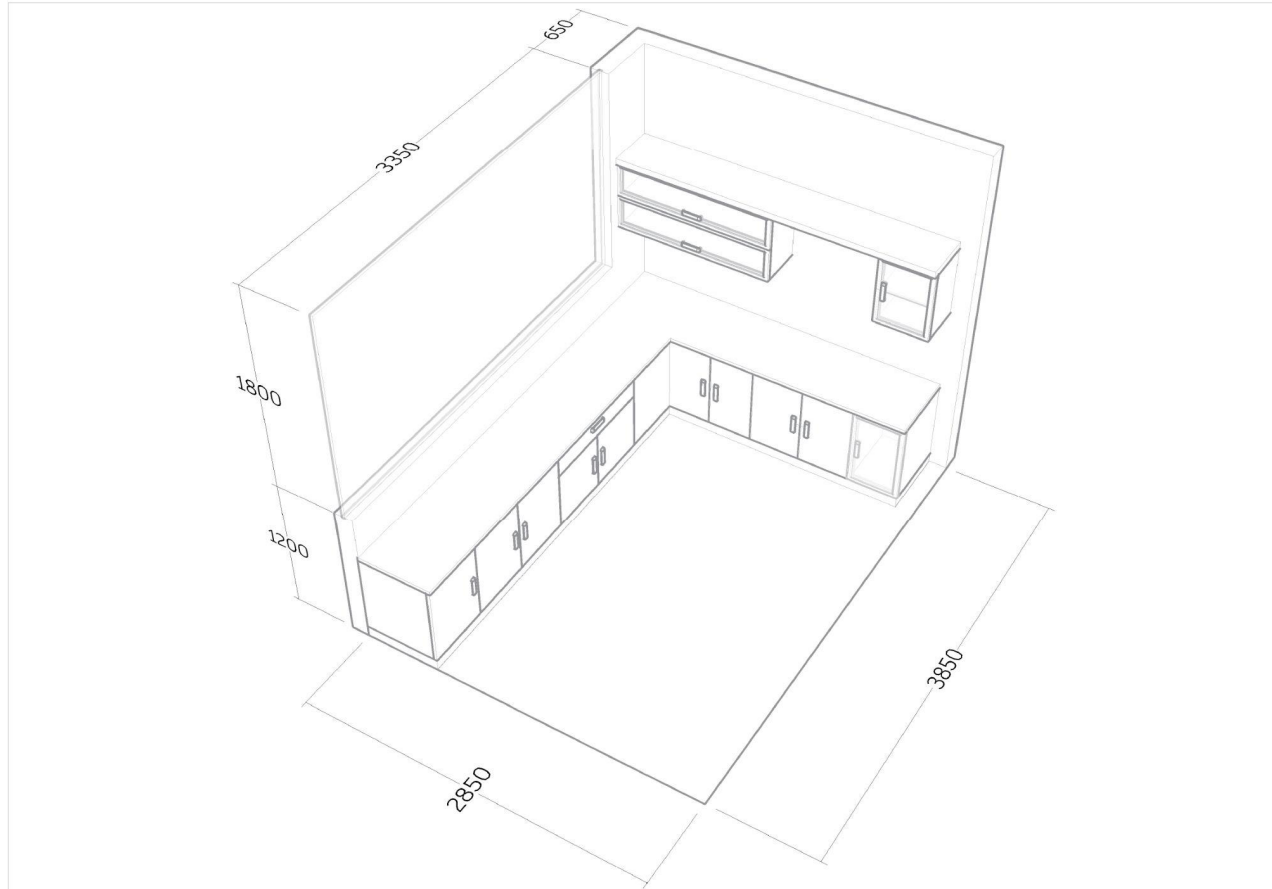

Module 5 - 2D Floor plan

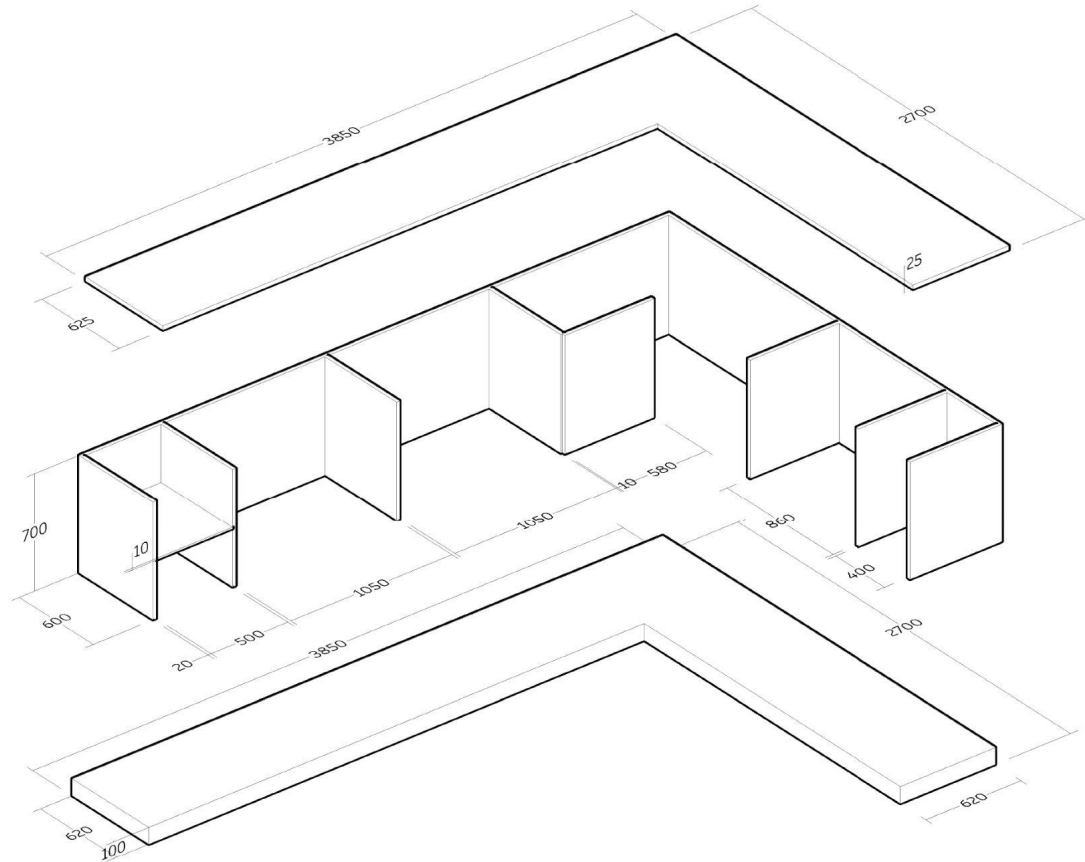

Module 5 - 2D Floor plan

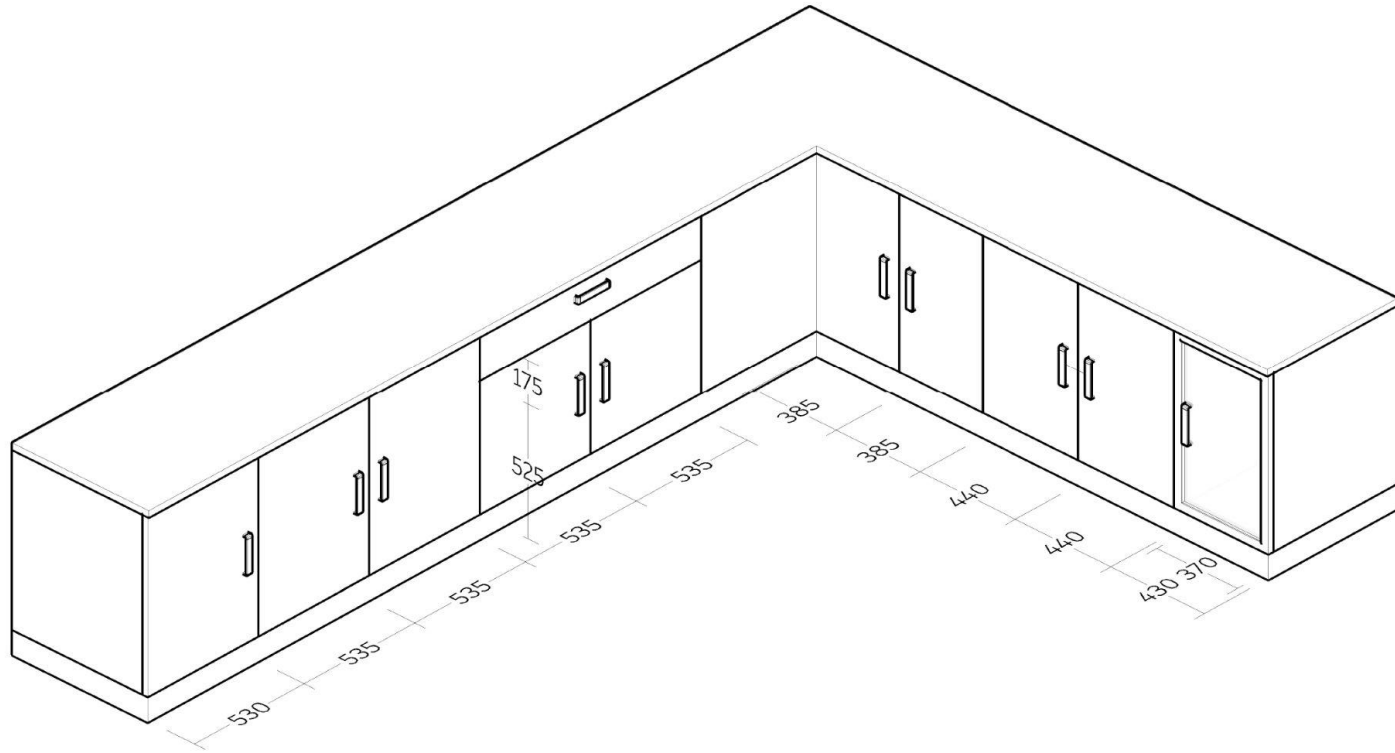

Module 5 - 2D Floor plan

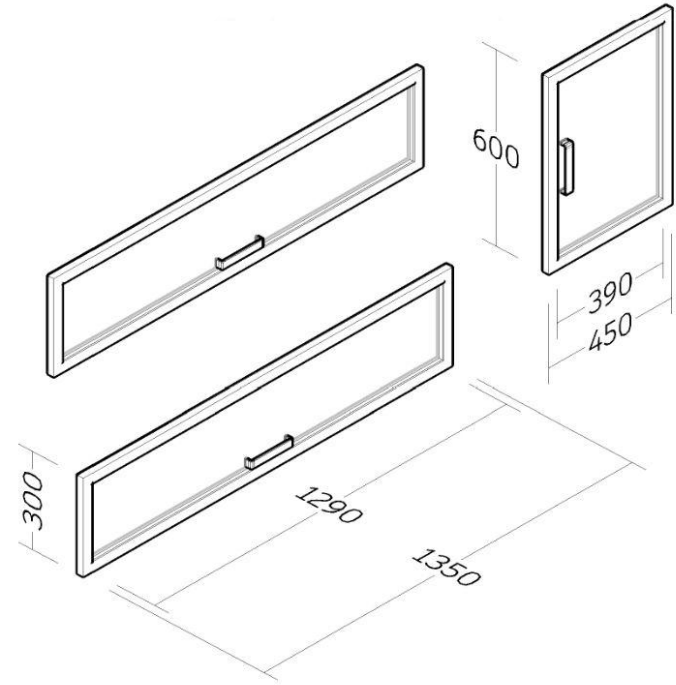
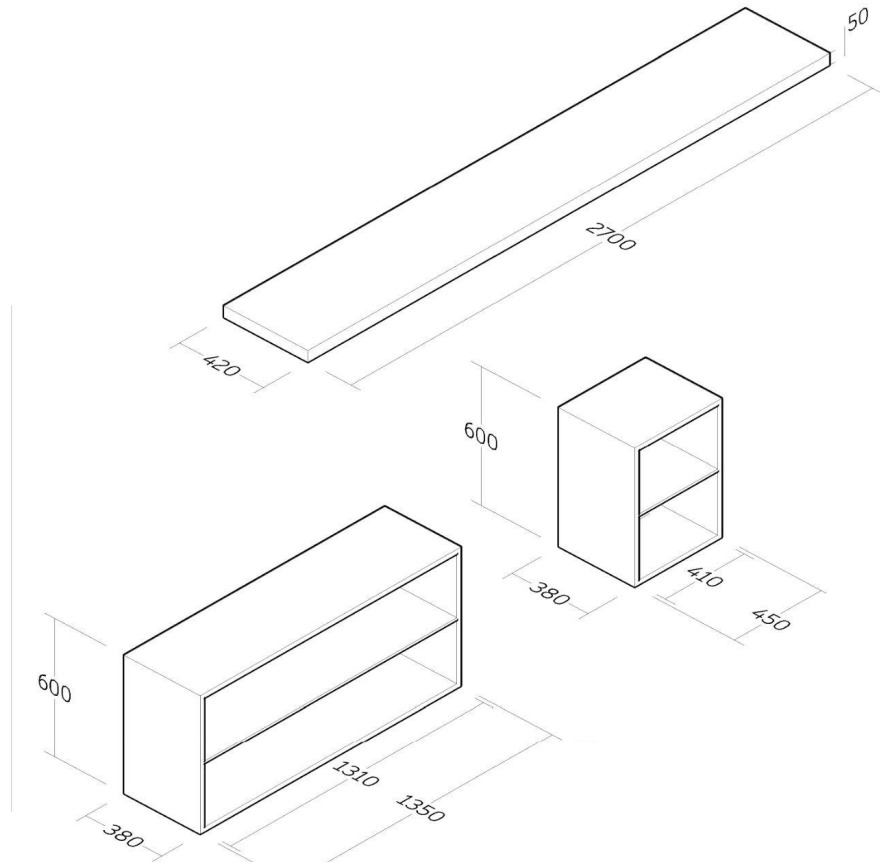

Module 5 3D Material Library

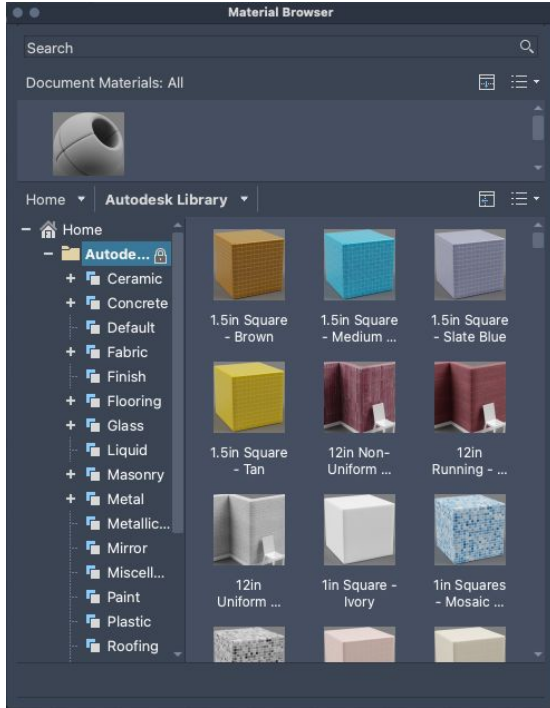

A **material library** **RMAT** is a collection of predefined materials and textures in design software that can be applied to 3D objects. It allows users to easily access various materials, such as wood or metal, enhancing the realism of their models by providing properties like color, reflectivity, and transparency. This streamlines the workflow and helps achieve accurate representations in designs.

Module 5 Environment Rendering Setup

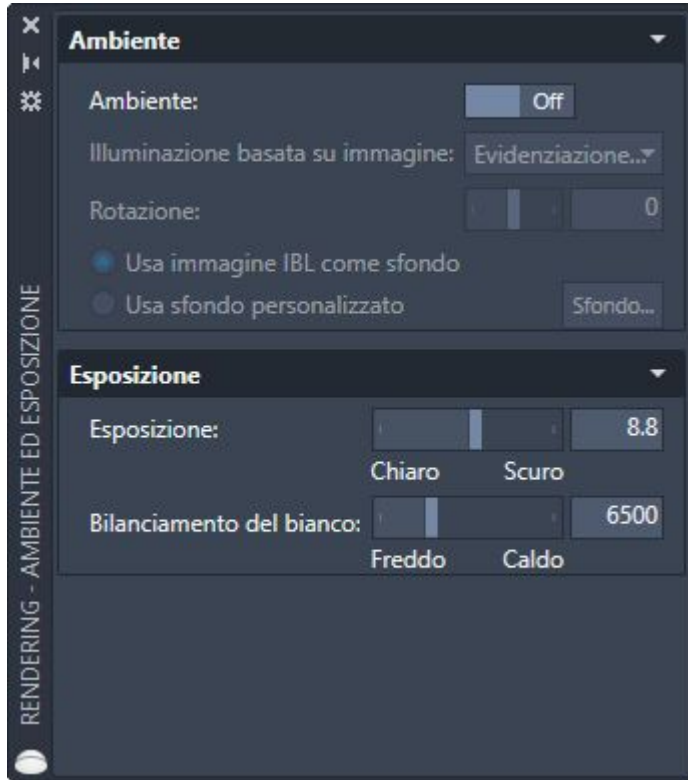

AutoCAD's rendering **RENDERE** setup involves configuring various settings to create high-quality images from 3D models. This process includes adjusting lighting, setting camera angles, applying materials and textures, and choosing the rendering environment. Users can control the intensity and color of light sources, apply shadows and reflections, and select the resolution and quality of the final output.

Module 5 Material Library

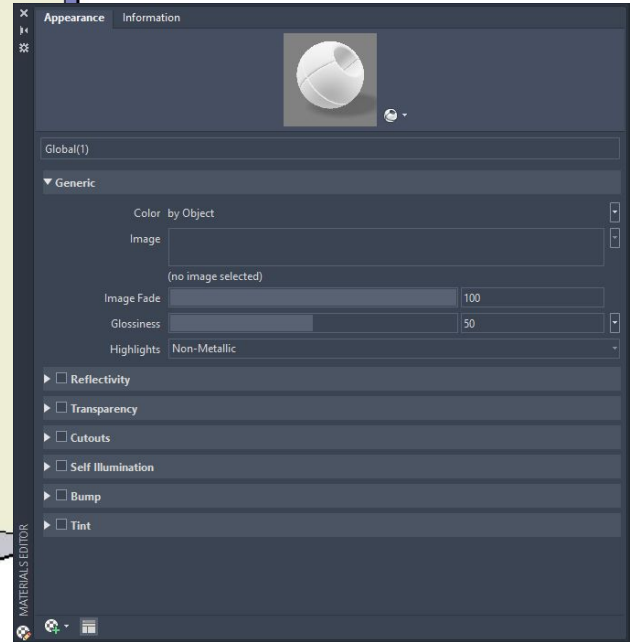
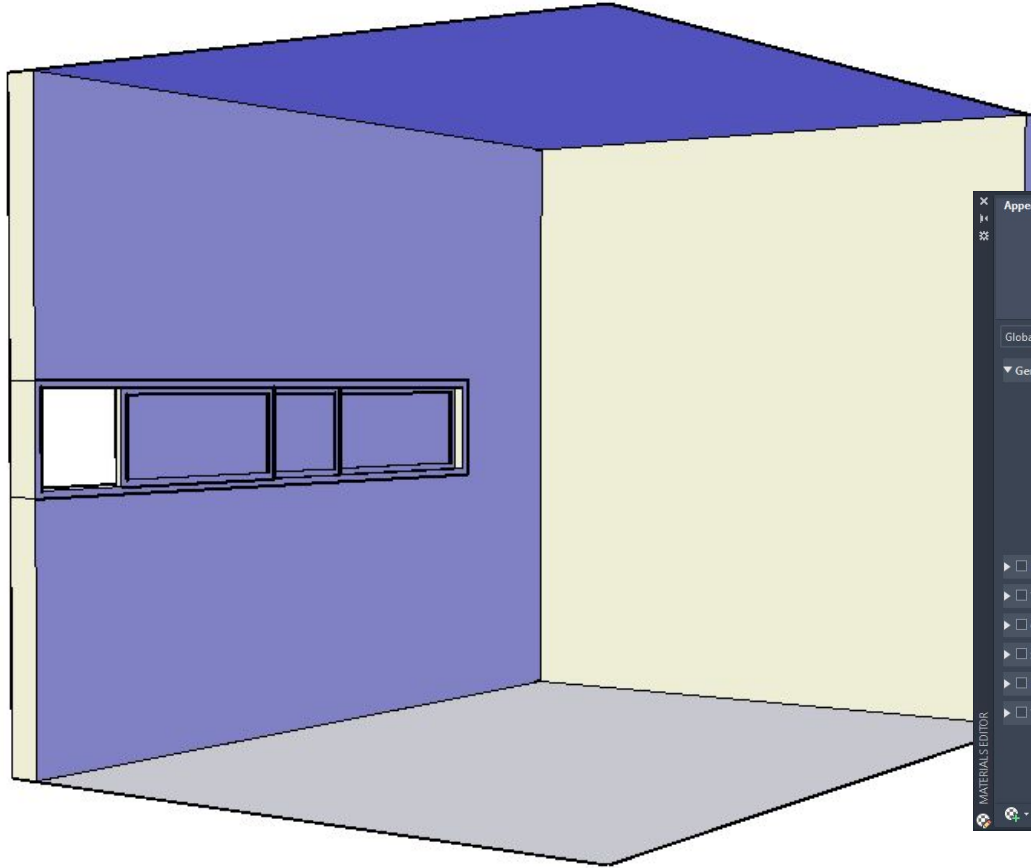

Module 5 Material Library

- Transparent Glass
- Solid Wood
- Reflection Board
- Metal

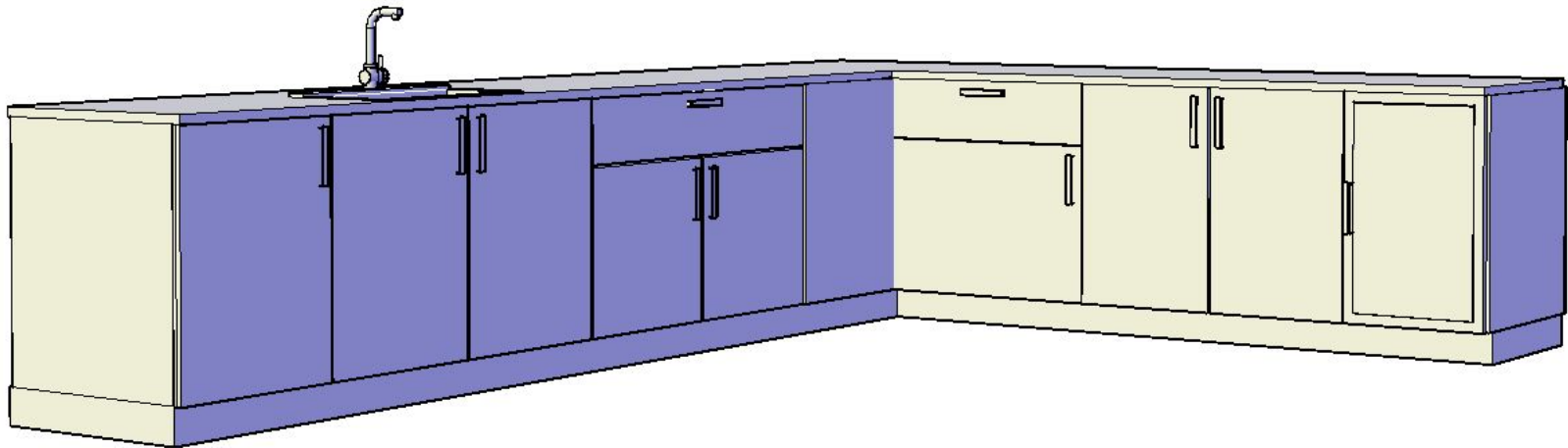
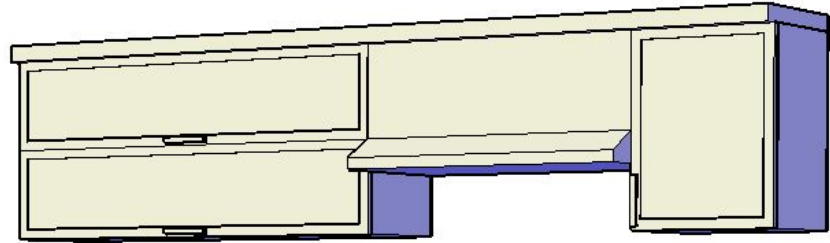

Module 5 Environment Rendering Setup

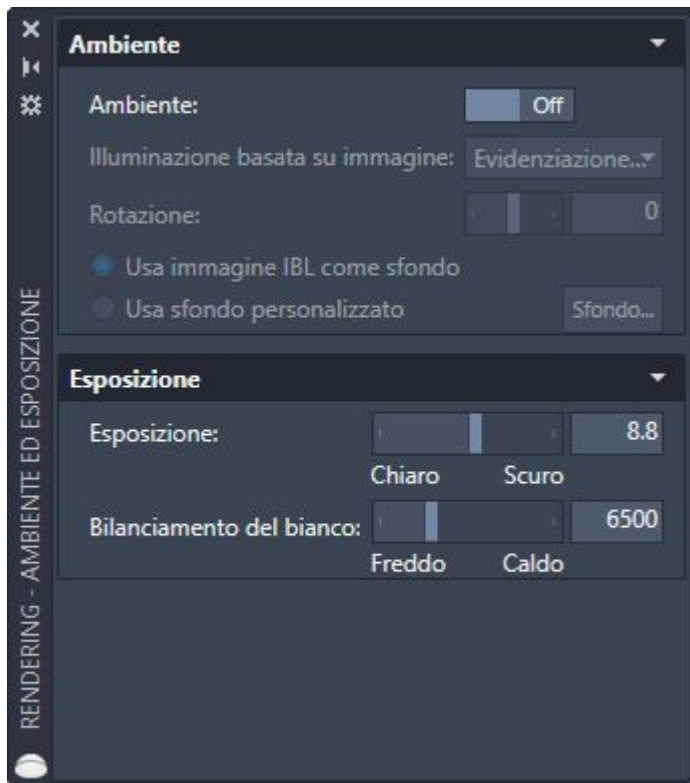

AutoCAD's rendering setup involves configuring various settings to create high-quality images from 3D models. This process includes adjusting lighting, setting camera angles, applying materials and textures, and choosing the rendering environment. Users can control the intensity and color of light sources, apply shadows and reflections, and select the resolution and quality of the final output. This setup is essential for producing lifelike images that accurately represent the design, providing a more tangible visualization of architectural or engineering projects. Proper rendering setup in AutoCAD is crucial for professionals to effectively communicate their designs and ideas.

ZWCAD



SMART MOUSE

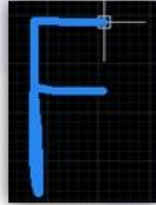
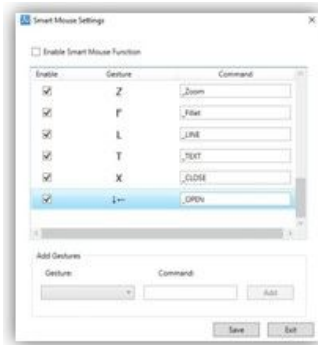

SMART SELECT

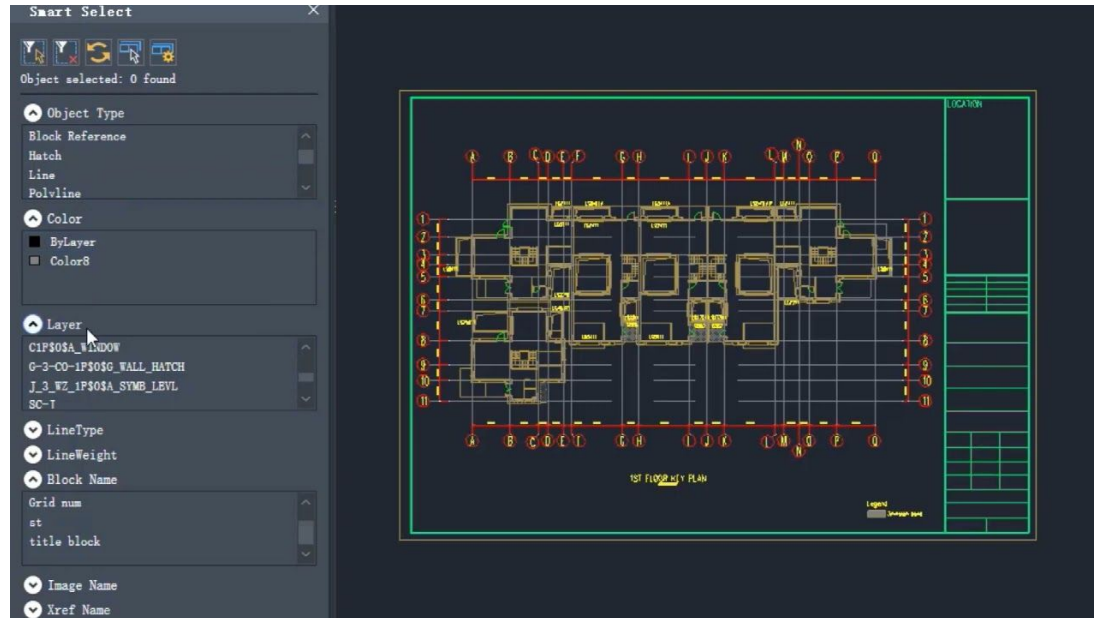

SMART PLOT

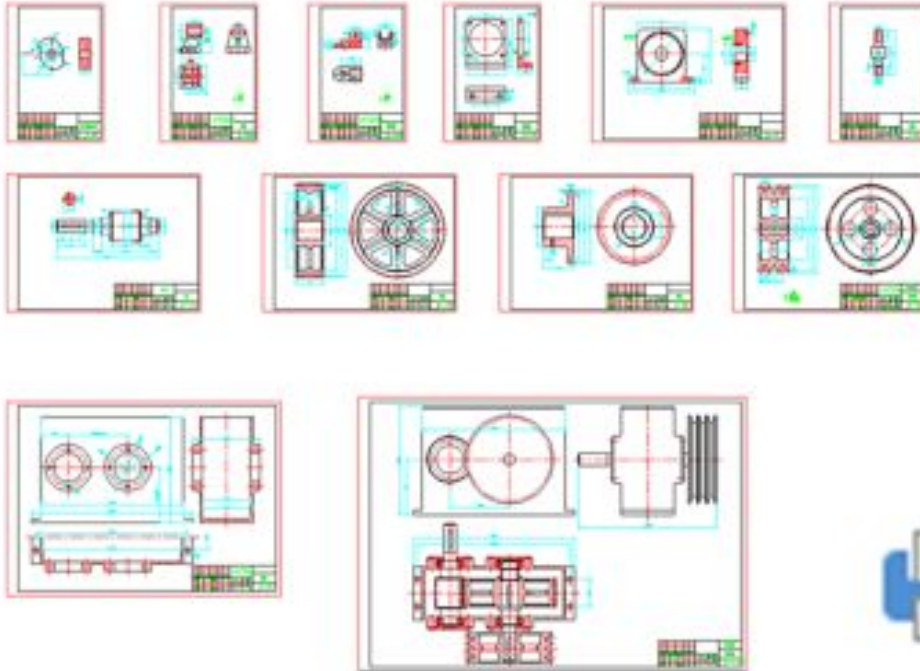

SMART VOICE



THANK YOU

Terima Kasih 谢谢 நன்றி ありがとう Merci
감사합니다 धन्यवाद 多謝你 Grazie ขอบคุณ Спасибо شكراً
لك

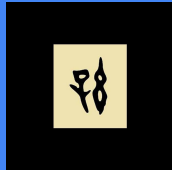

Benedict Soon

Facebook

Module 1.13 Fillet Skill

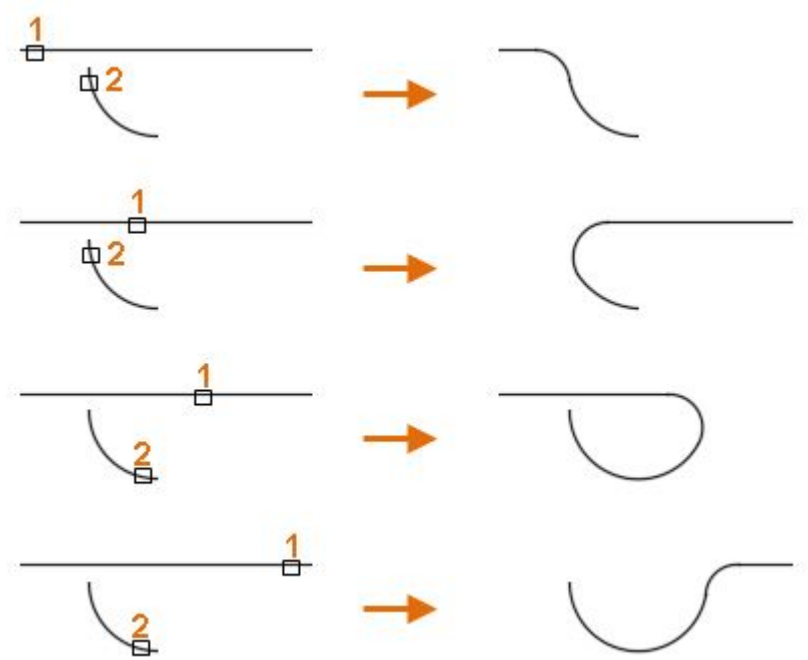
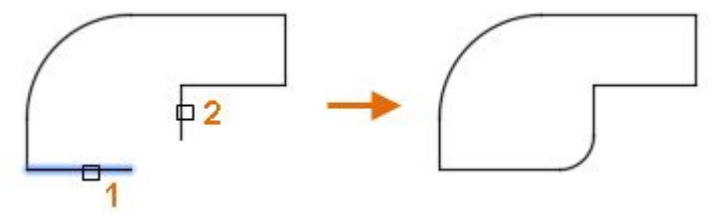
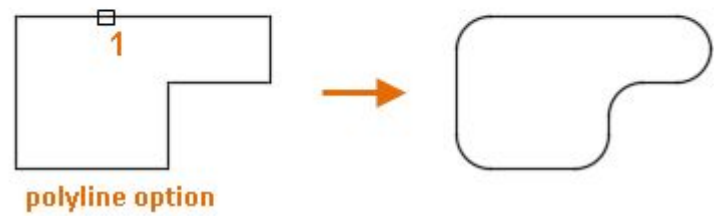
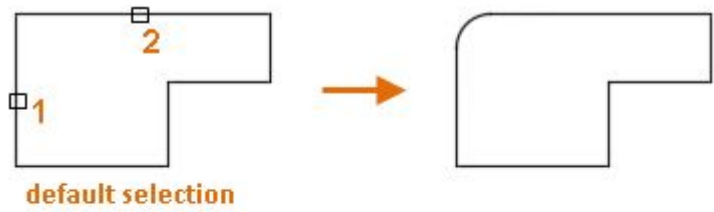

Module 2 Polar Array Setting

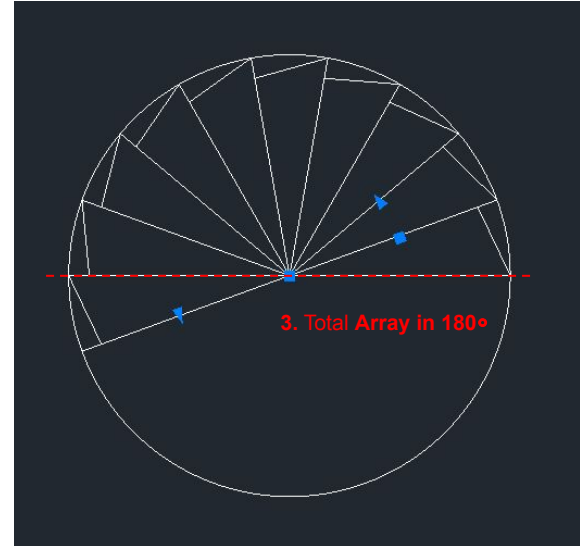
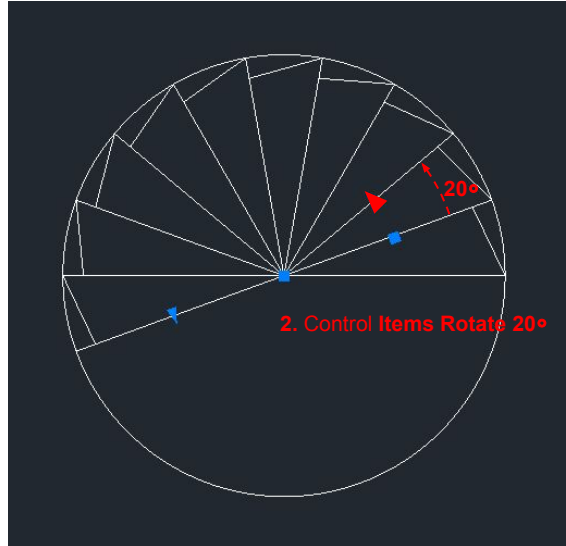
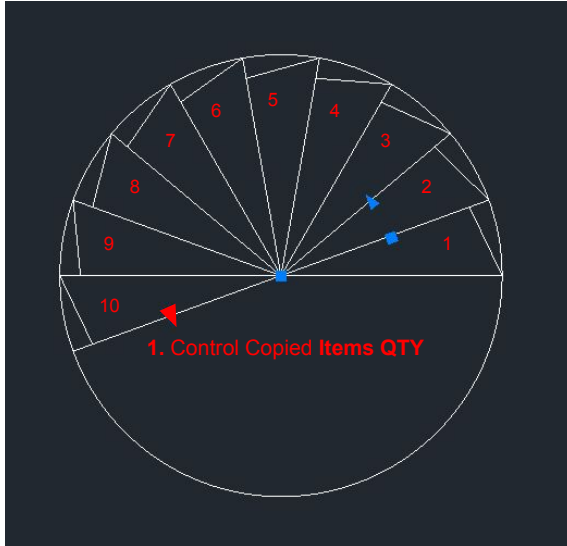

Polar	1	Items:	10	Rows:	1	Levels:	1	Associative	Base Point	Rotate Items	Direction	Close Array
	2	Between:	20	Between:	2827.7854	Between:	1					
	3	Fill:	180	Total:	2827.7854	Total:	1					
Type		Items		Rows		Levels		Properties		Close		

Module 1 Polar Tracking Line

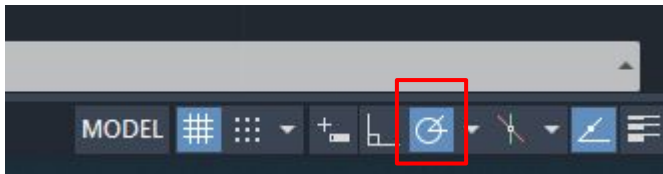
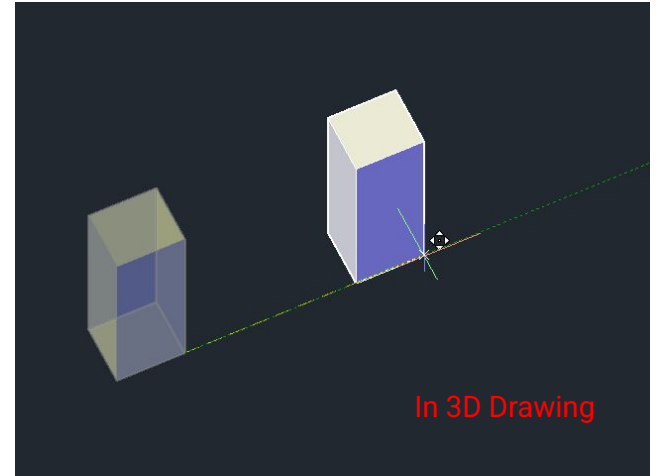
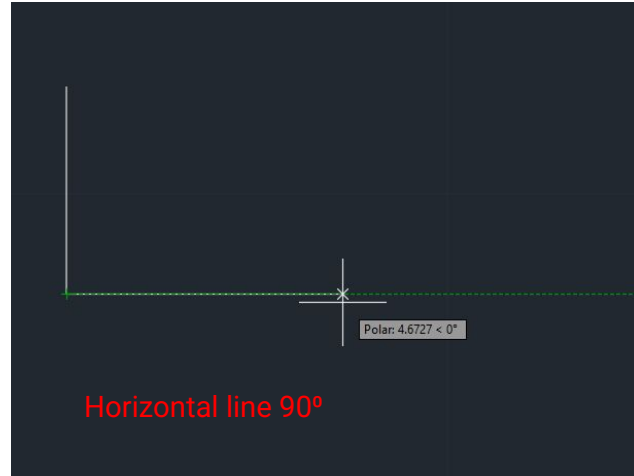
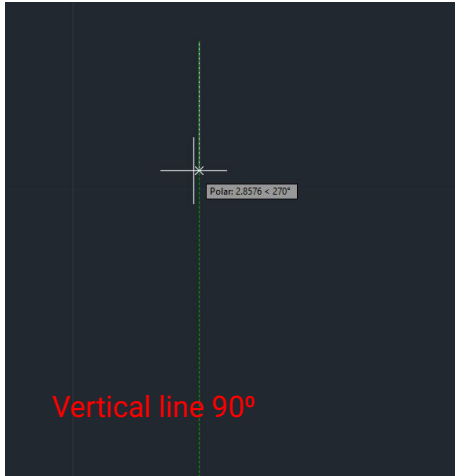

The **Polar Tracking Line F10** is a green indicator line that shows specified angles relative to the X, Y, or Z (3D) axis, helping to maintain precise alignment and direction when drawing or modifying objects.

Module 1 Circle Quadrant

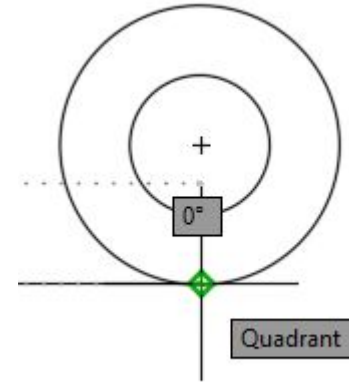
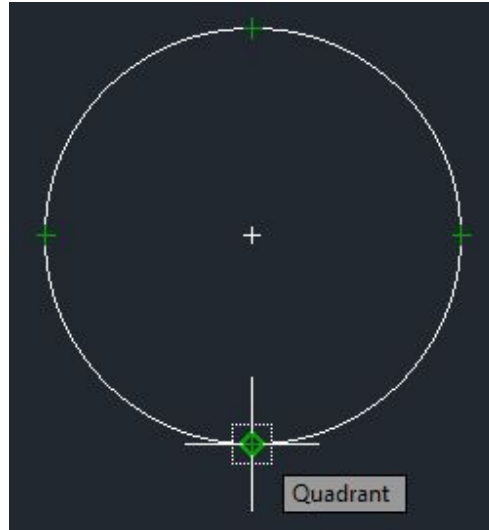
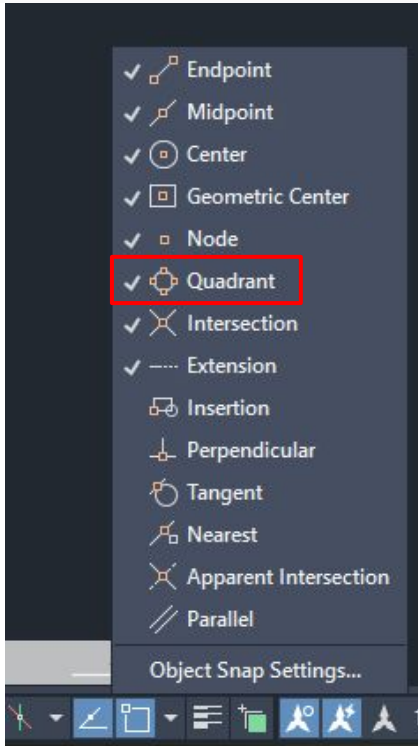

A **Circle Quadrant** refers to one of the four equal sections created when a circle is divided by its diameter.

Module 1 Circle Center

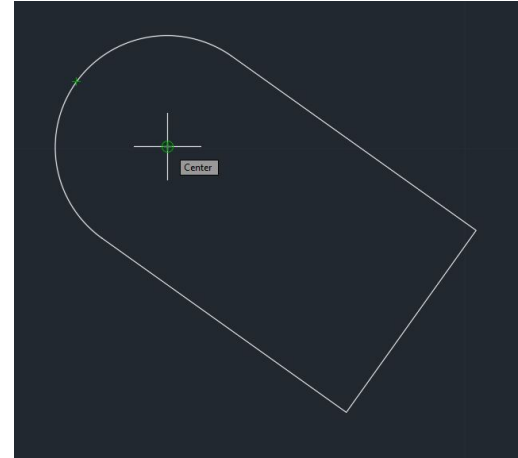
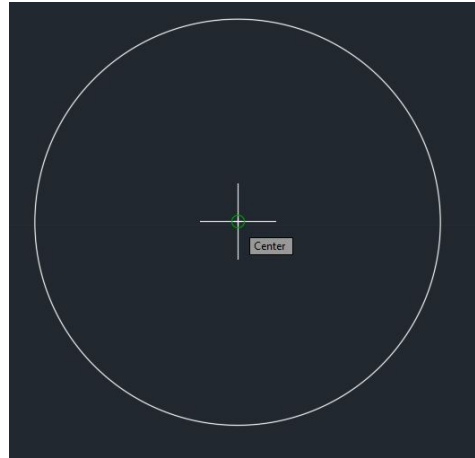
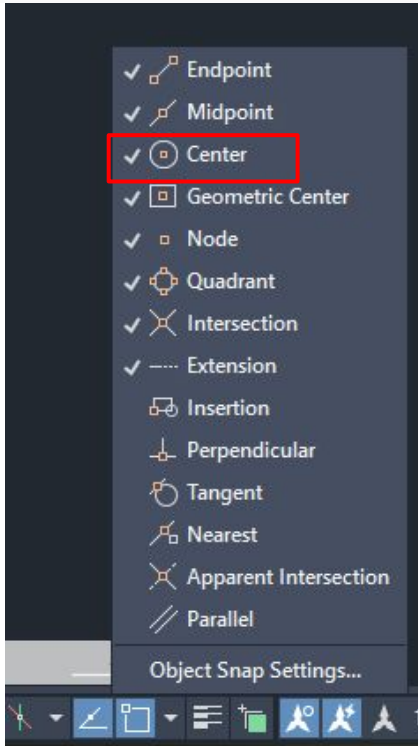

The **Circle Center** is the specific point around which the circle is defined, serving as the midpoint for its radius.

Break Time



11:00AM	-	11:15AM	Tea Break
12:30PM	-	1:30PM	Lunch Break
3:00PM	-	3:15PM	Break